

### FREE FALL ROPE AND CHAIN ANCHOR WINCH

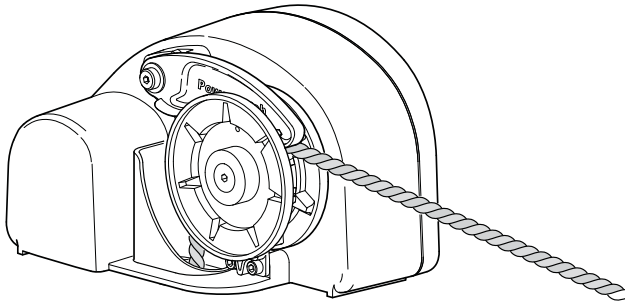

PW46101

- ◆ *12 Volt Powered Winch*
- ◆ *Power-In / Freewheel-out operation*



**Thoroughly read the manual furnished with this product and be familiar with the controls. Do not allow individuals to operate the winch without understanding the safe operation and procedures for the equipment.**

# PROPRIETARY STATEMENT

The *Powerwinch* Anchor Winch is a product of Scott Fetzer Electrical Group or SFEG, located in Fairview, Tennessee, USA. The information contained in or disclosed in this document is considered PROPRIETARY to SFEG. Every effort has been made to ensure that the information presented in the document is accurate and complete. However, SFEG assumes no liability for errors or for any damages that result from the use of this document.

The information contained in this manual pertains to the current configuration of the models listed on the title page. Earlier model configurations may differ from the information given. SFEG reserves the right to cancel, change, alter or add any parts and assemblies, described in this manual, without prior notice.

SFEG agrees to allow the reproduction of this document for use with SFEG products only. Any other reproduction or translation of this document in whole or part is strictly prohibited without prior written approval from SFEG.

## TABLE OF CONTENTS

<b>Safety Information</b> .....	<b>1</b>
<b>Specifications</b> .....	<b>1</b>
Davit/Bow Roller.....	2
Furnished Materials:.....	2
Required Materials (not included with winch) .....	2
Rope and Chain Rodes .....	3
Rope Locker.....	3
<b>Mounting the Unit</b> .....	<b>4</b>
<b>Wiring the Unit</b> .....	<b>6</b>
Testing the Unit .....	8
Loading the Rope and Chain Rode .....	8
<b>Operating the Anchor Winch</b> .....	<b>9</b>
Anchoring .....	9
Retrieving the Anchor.....	9
Maintenance.....	10
Troubleshooting Guide .....	10
<b>Replacement Parts List</b> .....	<b>11</b>
<b>Warranty</b> .....	<b>13</b>

## SAFETY INFORMATION

The following Safety Precautions Must be Followed at ALL Times. Failure to follow the warnings and cautions in this manual could result in serious injury and/or property damage.

 **WARNING** This product can expose you to chemicals including Di-isodecyl phthalate (DIDP), Vinyl Chloride and Cumene, which are known to the state of California to cause cancer or birth defects or other reproductive harm. For more information visit [www.P65warnings.ca.gov](http://www.P65warnings.ca.gov)

 **CAUTION** ALWAYS block the vehicle wheels to help prevent the vehicle from moving when pulling a load with the winch.

 **CAUTION** SHOCK HAZARD. ALWAYS unplug the wiring harness before attempting to install, relocate, service or perform maintenance on the winch.

 **CAUTION** NEVER use the winch to lift or move people or animals.

 **CAUTION** NEVER use the winch for overhead lifting.

 **CAUTION** NEVER attempt to pull a load greater than the rated load of the winch.

 **CAUTION** ALWAYS stand away from the winch during operation. ALWAYS keep objects, people and animals away from the camper and camper top when operating the winch. Serious injury could occur if the cable breaks.

 **CAUTION** NEVER wear loose fitting clothes, scarves, ties or jewelry when operating the winch. Loose clothing can become caught in moving parts.

 **CAUTION** ALWAYS keep hands clear of the cable spool (drum area).

 **CAUTION** ALWAYS wear leather gloves when handling the rope and chain.

 **CAUTION** ALWAYS tie off the anchor to a secure mount (e.g. a deck cleat) for storage and after lowering the anchor. NEVER use the winch to tie off the anchor.

 **CAUTION** ALWAYS stand away from the winch during operation. ALWAYS stand clear of the area behind and between the load and the winch. Serious injury could occur if the rope breaks.

 **CAUTION** NEVER place foreign objects in the gypsy while retrieving or free falling the anchor. Serious injury can occur.

SPECIFICATIONS

## DAVIT/BOW ROLLER

This product requires the use of a closed loop davit or bow roller. Davit or bow roller must be installed prior to installing anchor winch to ensure proper performance.

 **CAUTION** Use of a davit with an open loop is not recommended with this product. Use a davit with a closed loop to prevent serious personal injury and/or property damage.

## FURNISHED MATERIALS:

qty	Description	qty	Description
1	Anchor Winch	1	25A Circuit Breaker
3	5/16-18 x 3.5 Stud	1	Switch Plate
3	5/16 Lock Washer	4	#10 x 3/4 Screw
3	5/16 Flat Washer	1	Switch, DPDT
3	5/16-18 Nut	1	Mounting Template

## REQUIRED MATERIALS (NOT INCLUDED WITH WINCH)

- Marine grade plywood for under deck support (optional).
- Loctite 242 thread locker or equivalent (optional).
- Silicone sealant.

**REQUIRED MATERIALS FOR ELECTRICAL INSTALLATION**

The following items are required for the electrical installation Sport Fishing 450 winch. These items are furnished by the installer.

Qty	Description	
2 ft	12 awg RED Wire Class 105°C	
2 ft	12 awg BLACK Wire Class 105°C	
70 ft	6 awg RED Wire Class 105°C	6 awg wire is the "run" wire from anchor to switch and battery to switch. Length is based on installation.
70 ft	6 awg BLACK Wire Class 105°C	
10	5/16" 6 awg ring terminals	
4	5/16" 12 awg ring terminals	
4	1/4" 12 awg insulated female spade quick disconnects	
6	1/4-20 x 1/2 Screws	Screws and nuts should be stainless steel to avoid rust and corrosion.
6	1/4-20 Nuts	
	Wire ties	
2 ft	1" diameter heat shrink	
2 ft	2" diameter heat shrink	

**ROPE AND CHAIN RODES**

This product is designed to raise and lower anchors using spliced rope and chain rode (a rode is a length of rope and chain). It is very important that only sizes and brands of spliced rope and chain rode specified below are used. Use of non-specified ropes and chains could cause reduced levels of performance or serious personal injury and/or property damage.

**Recommended Rope and Chain Rodes**

REQUIRED ROPE	REQUIRED CHAIN
1/2" Diameter, 3 strand, medium lay, premium nylon Powerwinch rope or New England Rope	1/4" Acco G4 Hi-Test chain.

**NOTICE** Use only spliced rope and chain rode. Shackles should never be used to secure rope to chain. Shackles will damage winch and void warranty.

**CAUTION** ALWAYS use the recommended rope and chain rode. Use of different rope can cause property damage and personal injury.

Rope and chain rode are sold separately and not included with winch.

**ROPE LOCKER**

The anchor winch must be positioned above a rope locker. The anchor line and chain feed into the rope locker through a deck insert (rode glide) mounted through the deck. Minimum locker dimensions for storage of lines are shown.

Line Dimensions	Locker Dimensions L x W x D
1/2" x 200'	15" x 17" x 12"
1/2" x 300'	15" x 24" x 12"

MOUNTING THE UNIT

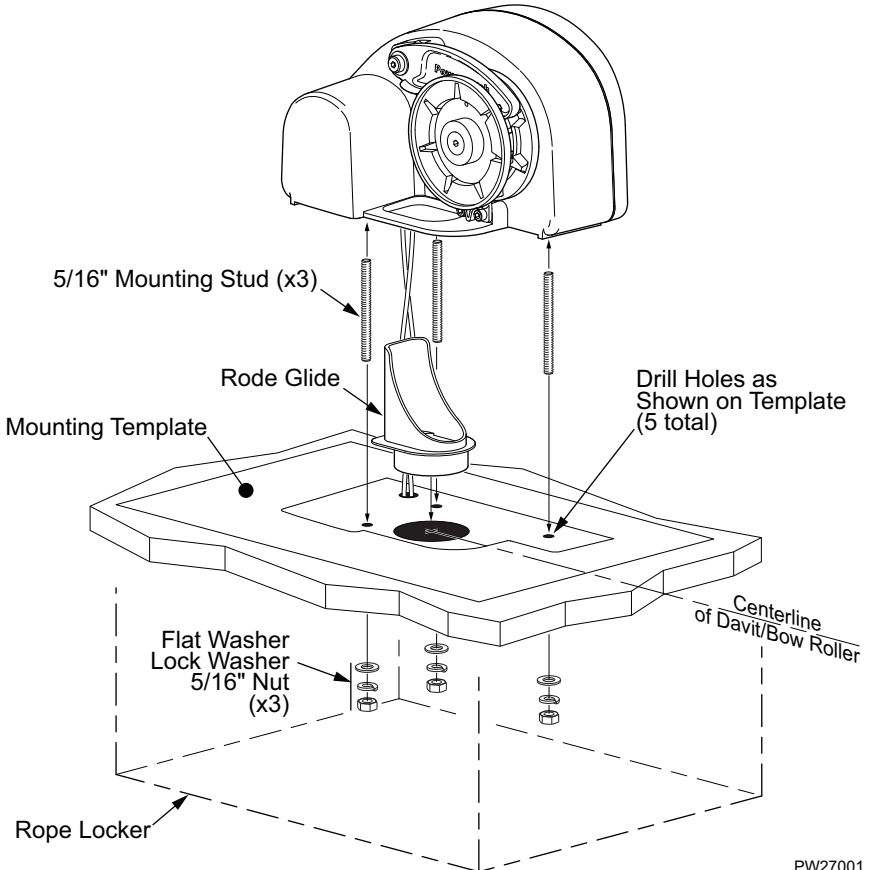
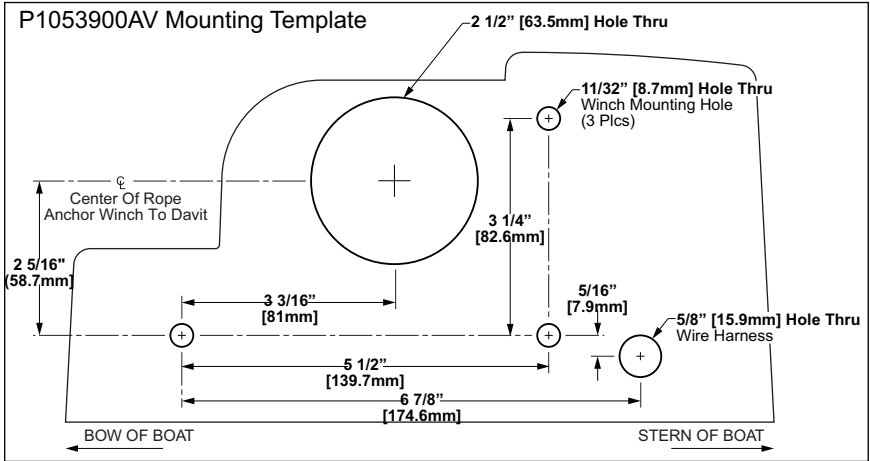

PW27001

1. Place the mounting template on the deck in the desired location and secure with tape.
  - The winch must be placed above the rope locker.
  - The centerline of the gypsy must line up with the centerline of the davit or bow roller.
2. Drill the holes as marked on the template.
3. Remove the template.
4. Place a bead of silicone sealant around the base of the rode guide. Insert the rode guide into the 2 1/2" hole. The half-moon cut out must face the davit or bow roller.
5. Use a small amount of thread locker and thread the 5/16-18 x 3 1/2" studs into the winch. Hand tighten until snug.
6. Align the winch over the rode glide and align the studs with the holes in the deck. Insert the wires through the hole in the deck. Lower the winch to the deck.
7. Under the deck, secure the winch to the deck use one (1) each 5/16 flat washer, 5/16 lock washer and 5/16 nut on each of the studs. Tighten the nuts to secure the winch to the deck.

## WIRING THE UNIT

**! WARNING** **SHOCK HAZARD.** ALWAYS disconnect the battery before working on electrical equipment.

**! WARNING** ALWAYS use the recommended wire size and rated circuit breakers. Failure to use the furnished and recommended sizes can cause a fire hazard and void warranty.

**NOTICE** When routing the wiring, avoid sources of heat.

**NOTICE** When routing the wiring, avoid sharp edges that can cut or fray the wire insulation.

1. Locate a suitable location for the switch. Ensure that there is adequate room behind the mounting surface for the switch and wiring.
2. Cut a 1" x 1 3/4" hole into the surface.
3. Press the switch into the switch plate until the locking tabs click into place.

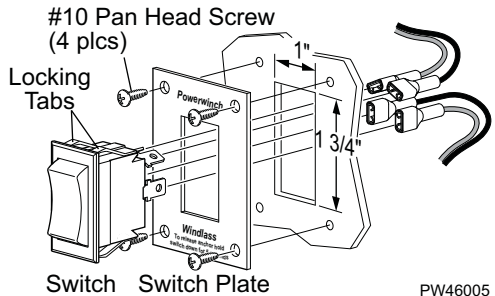

4. Cut two (2) each 12" long pieces of the RED and BLACK 12 awg wire.
5. Terminate one end of each wire with a 12awg 1/4" female disconnect. Ensure that the crimp is solid and cannot pull off.
6. Terminate the other end of each wire with a 12awg 5/16" ring terminal.
7. Connect the wires to the switch using the female disconnects as shown in the wiring diagram (see next page).
8. Set switch aside.
9. Route one RED and one BLACK 6 awg wire from the anchor to the switch location. Be sure to allow adequate wiring to make connections, allow the wire to have some slack when routing. Secure the wires with wire ties.
10. At the winch position, terminate the wires from the winch and the ends of the new wires with 5/16" 6 awg ring terminals.

*Tip: Before making the mechanical connection, slide a 2 1/2" piece of the shrink tubing over one wire. Make the connection then slide the wrap over the connection. Lightly heat the wrap until it shrinks around the terminals.*



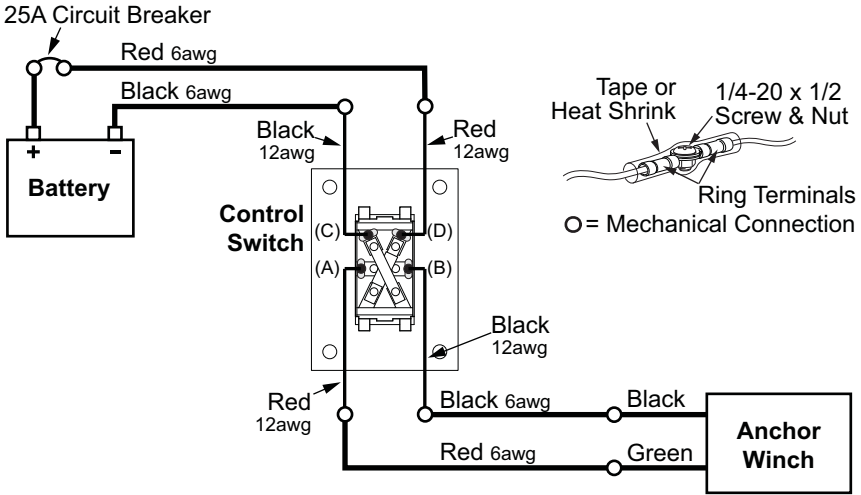

PW46004

11. Connect the motor GREEN wire to the new RED wire with a 1/4 -20 screw and nut. Position the wrap and lightly heat until it shrinks around the terminals.
12. Connect the motor BLACK wire to the new BLACK wire with a 1/4 -20 screw and nut. Position the wrap and lightly heat until it shrinks around the terminals.
13. At the switch position, terminate the ends of the new wires with 5/16" 6 awg ring terminals.
14. Connect the switch RED wire to the winch RED wire with a 1/4 -20 screw and nut. Position the wrap and lightly heat until it shrinks around the terminals.
15. Connect the switch BLACK wire to the winch BLACK wire with a 1/4 -20 screw and nut. Position the wrap and lightly heat until it shrinks around the terminals.
16. Route 1 RED and 1 BLACK 6 awg wire from the battery to the switch location. Be sure to allow adequate wiring to make connections, allow the wire to have some slack when routing. Secure the wires with wire ties.
17. At the switch position, terminate the ends of the new wires with 5/16" 6 awg ring terminals.
18. Connect the switch RED wire to the battery RED wire with a 1/4 -20 screw and nut. Position the wrap and lightly heat until it shrinks around the terminals.
19. Connect the switch BLACK wire to the battery BLACK wire with a 1/4 -20 screw and nut. Position the wrap and lightly heat until it shrinks around the terminals.
20. Push the switch and wires into the switch mounting hole. Secure the switch plate using 4 #10 screws.
21. At the battery location, terminate each wire with a 5/16" ring terminal.
22. Attach the BLACK wire to the negative (-) post of the battery.
23. Attach the RED wire to the post on the circuit breaker.
24. Attach the circuit breaker to the positive (+) post of the battery.

**TESTING THE UNIT**

1. Ensure that all connections are secure and correct. For the 46' make sure that the in-line fuse is installed in the Red wire between the switch and relay module.
2. Without rope or chain in gypsy, press and hold switch in upward position. If wiring to switch terminals is correct, gypsy will spin counterclockwise. If gypsy does not turn, but motor runs, switch is incorrectly wired. To correct, switch the black and white wires on back of the switch.

**LOADING THE ROPE AND CHAIN RODE**

*(Refer to the rope and chain requirements on page 3.)*

1. Feed rope through davit or bow roller and pull toward anchor winch. Make sure rope is not twisted or kinked and can freely run through bow roller or davit.
2. Lift finger and insert rope into rode glide and down into rope locker. Allow enough slack so rope can be tied off in rope locker.
3. Release finger and make sure rope is firmly seated in the gypsy.
4. Go below to rope locker and tie rope off.
5. Press switch up and begin retrieving rope and chain into rope locker.

---

## OPERATING THE ANCHOR WINCH

**CAUTION**

**NEVER** use the winch to exclusively hold, support or permanently secure the load. **ALWAYS** secure the rope to a deck cleat or similar device.

**NOTICE**

**To prevent damage to the motor, do not operate the winch continuously for periods over 20 minutes. Allow the motor to “rest” for a minimum of 1 hour.**

### ANCHORING

1. Turn boat into wind and place boat motors in neutral.
2. After the boat has stopped all forward progress, drop anchor by pressing the winch switch in the down position for approximately 5 seconds. After the anchor has begun to free-fall it is safe to release the switch.

**NOTICE**

**Never reverse the winch while the unit is in free-fall mode.**

3. After the desired amount of rope has been release, retrieve 3'-5' of line by pressing the switch in the up position.
4. Tie the rope off to a deck cleat. DO NOT use the winch to tie-off the anchor.
5. Place the boat's motors in neutral and allow the boat to drift back and set the anchor in the sea bed.

### RETRIEVING THE ANCHOR

1. Untie the rope from the deck cleat.
2. Align bow of boat with anchor rode.
3. Place the boat's motors in forward and move boat slowly toward the anchor point. While moving press the winch switch in the UP position.

**NOTICE**

**Do not pull the boat to the anchor point with the anchor winch. This can cause damage to the winch motor and gear train. Always use the boat motor to move toward the anchor point.**

4. When the chain begins enter gypsy, the rode is almost retrieved. Do not allow the anchor to pull up to quickly into the davit or bow roller.
5. When the anchor reaches the davit or bow roller, do not place too much tension on the chain between the winch and anchor. This can cause damage to the davit or winch gypsy.
6. Tie off the anchor for storage and travel.

## MAINTENANCE

Following each boat outing, flush exterior of winch with fresh water. Use only mild detergents to clean exterior. Use of solvents can cause damage to the finishes and seals, as well as void product warranty.

Every 6 months inspect gypsy, stripper, finger and deck insert for wear. Replace any worn components.

Check electrical connections every 6 months for corrosion. Replace any connection or wire which is damaged, corroded, frayed or worn.

Check rope periodically for abrasion or deep cuts. Never splice an old rope with a new rope. If replacement is necessary, use only Powerwinch® rope specifically designed for this product.

Check chain periodically for bent links and corrosion. Damaged links can become jammed in gypsy or damage stripper and finger. Use of damaged chain will void warranty.

## TROUBLESHOOTING GUIDE

<b>WINCH DOES NOT OPERATE</b>			
A.	Confirm power to winch 1. Check battery is fully charged 2. Confirm connections are tight & clean. 3. Check wires if worn or bare that may cause shorts		Correct as required.
B.	Check circuit breaker at battery Bypass circuit breaker and test winch. Does the winch run?	YES	If winch runs, circuit breaker is bad, replace.
	<b>NOTICE</b> Do not operate the winch without the circuit breaker. Removing the CB from the circuit is ONLY for testing.	NO	Reconnect circuit breaker and go to step C.
<b>ROPE SLIPS OR JAMS WHEN RETRIEVING</b>			
A.	1. Wrong rope size.	Replace rope. Refer to page 3 for recommended rope.	
	2. Rope is frayed and worn.		
	3. Rope is too stiff.		
<b>CHAIN SLIPS OR JAMS</b>			
A.	1. Wrong chain size.	Replace chain. Refer to page 3 for recommended chain.	
	2. Links are bent or corroded.		
	3. Chain is kinked	Unkink chain	
<b>ANCHOR LINE WILL NOT FREE-FALL</b>			
A	1. Rope tangled in rope locker	Untangle rope, Be sure rope is not kinked or twisted before anchoring	
	2. Chain is kinked	Unkink chain.	
	3. Anchor is wedged in bow roller	Free anchor	

REPLACEMENT PARTS LIST

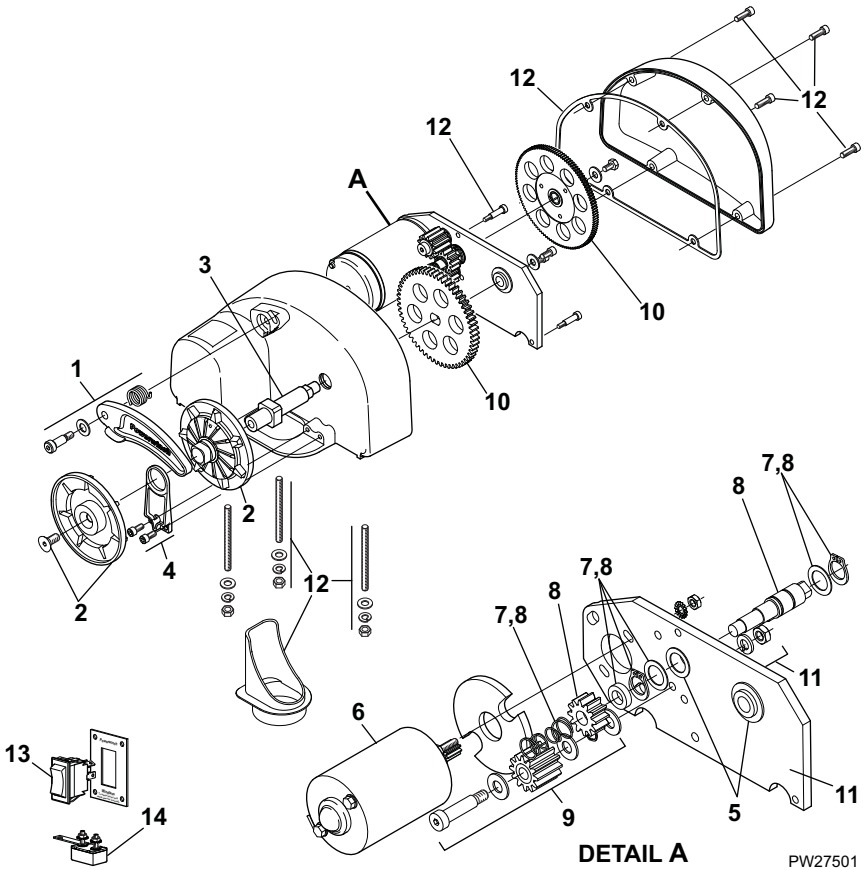

PW27501

<i>Item</i>	<i>Description</i>	<i>Description</i>	<i>Notes</i>
1	R001430	Finger Kit	1
2	R001431	Gypsy Kit	
3	P10341	Gypsy Shaft Kit	
4	R001432	Stripper Kit	
5	P10343	Bearing Kit	
6	R001434	Motor Kit	
7	R001435	Shock Absorber Kit	
8	R001436	Spin Off Gear Kit	
9	R001437	Locking Gear Kit	
10	R001438	Gear Kit	
11	R001440	Motor Plate	
12	R001439	Fastener Kit	
13	R001441	Switch Kit	
14	P1027600AJ	Circuit Breaker, 25A	

Notes: 1. Spin Off Gear Kit (item 8) includes shock absorber kit (item 7).

The following rope and chain rodes are available from Powerwinch.

<i>Part Number</i>	<i>Chain</i>	<i>Rope</i>	<i>Model Use</i>
P10293	1/4 in. x 10 ft.	1/2 in. x 150 ft.	36'
P10294	1/4 in. x 15 ft.	1/2 in. x 200 ft.	36'
P10295	1/4 in. x 15 ft.	1/2 in. x 300 ft.	36'
P10296	1/4 in. x 20 ft.	1/2 in. x 300 ft.	36'

## WARRANTY

SFEG warrants to the FIRST retail Purchaser that the Powerwinch Product described in this manual is free of defects in material and workmanship within the terms and conditions as set forth below. SFEG's obligation under this warranty is limited to the repair or replacement, at SFEG's option, of any defective component within the stated warranty period. THIS WARRANTY IS NOT TRANSFERABLE.

### 1. DURATION

- a) 2 years on parts and labor.
- b) SFEG will pay the transportation charges for return shipment to the purchaser of any product received for legitimate warranty repair.

Warranty duration is not extended by the length of time the product is not in use or the time that the purchaser is deprived the use of the product. The duration of coverage is determined by the date of the original product purchase, not the date of repairs.

### 2. WHAT IS COVERED UNDER THIS WARRANTY

Defects in the manufacturer's material and workmanship of product under normal use, and which occur within the duration of the warranty period.

### 3. WHAT IS NOT COVERED UNDER THIS WARRANTY

- a) Improper installation and/or any consequent damage or failure that results from improper installation of the product.
- b) Normal wear.
- c) Conditions that are not related to the material or workmanship of the product: including any failure that results from an accident, wind, rain, or other acts of God.
- d) Purchaser's abuse, including but not limited to neglect; failure to operate, use or maintain the product in accordance with the instructions provided with the product.
- e) Any component not sold or manufactured by SFEG.
- f) Any failure that results from the use of another manufacturer's product with a SFEG product that is not specifically approved by SFEG.
- g) Any incidental, indirect, or consequential loss, damage or expense that may result from any defect, failure or malfunction of the product.
- h) The removal or alteration of any product component or device. In the event of such removal or alteration, this warranty is void.
- i) Any expense related to delivery or pick-up of product to/from the service dealer.

### 4. RESPONSIBILITIES OF THE PURCHASER

IN ORDER FOR THE WARRANTY TO BE HONORED, THE PURCHASER MUST HAVE PROOF OF PURCHASE. FAILURE TO PROVIDE THE REQUIRED DOCUMENTATION MAY DELAY OR VOID ANY WARRANTY CLAIM.

- a) Retain dated proof of purchase for the product, and provide it as requested.
- b) Perform "Periodic Maintenance" as specified in Owners Manual.
- c) Use reasonable care in maintenance, operation, use and storage of the product in accordance with the instructions contained in the owner's manual.

**THIS WARRANTY GIVES THE OWNER SPECIFIC LEGAL RIGHTS. THE LAWS OF CERTAIN JURISDICTIONS MAY GRANT THE OWNER ADDITIONAL RIGHTS AND PRIVILEGES.** Except as set forth above; SFEG makes no warranty, whether statutory or otherwise, including without limitation, any warranty of merchantability or fitness for a particular purpose. SFEG shall have no liability except to repair, replace or adjust defective products and parts. SFEG specifically excludes any liability, whether in contract, tort or otherwise, for personal injury, property damage, economic or consequential losses. SFEG has not authorized any person or company to alter the terms of this warranty.

It is SFEG's policy and practice to continuously improve the company's products and services. Therefore, SFEG reserves the right to make changes in design and components, without notice, whenever it is believed the quality of the product will be improved, but without incurring any obligation to incorporate such improvements in any product which has been shipped or in service.

