

Please read and save these instructions. Read carefully before attempting to assemble, install, operate or maintain the product described. Protect yourself and others by observing all safety information. Failure to comply with instructions could result in personal injury and/or property damage! Retain instructions for future reference.



## Multi-Purpose Winch

### Description

Multi-purpose winches are used to pull heavy loads horizontally from one point to another. The QC series features a quick-connecting wiring harness for portability and fast installation.

### Unpacking

When unpacking this product, carefully inspect for any damage that may have occurred during transit.

### General Safety Information

The following safety precautions must be followed at all times:

1. Read all manuals included with this product carefully. Be thoroughly familiar with the controls and the proper use of the equipment. Only persons well acquainted with these rules of safe operation should be allowed to use the winch.
2. Never use the winch to lift or move people or animals.
3. Stand away from the winch when in use and keep children free from winch area at all times.

**▲WARNING** Always stand clear of the area behind and between the load or anchor point and the winch. Serious injury could occur, if the cable breaks.

4. Always keep hands clear of cable spool (drum area).
5. Do not wear loose fitting clothing, scarves, or neck ties. Loose clothing may become caught in moving parts and result in serious personal injury.
6. Do not use the winch as a hoist.

Model AP1500

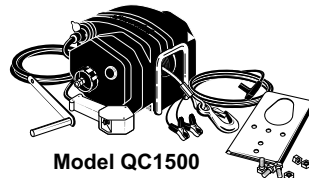
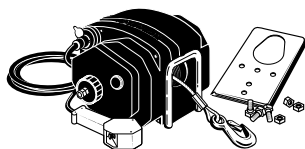

Model QC1500

Model QC3500

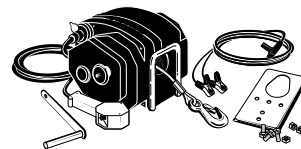

Model AP3500

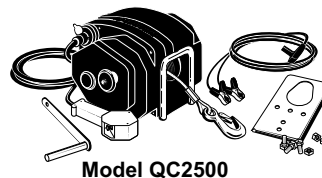
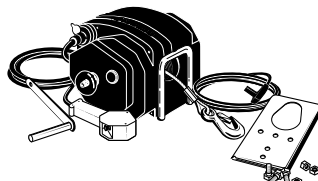

Model QC2500

Model QC4500

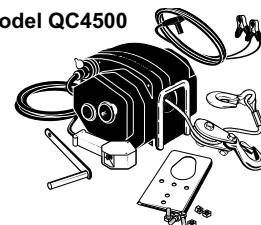

- Never use the winch for overhead lifting.
7. Always use the winch with circuit breakers. Failure to use the breakers could cause overheating thus creating a potential fire hazard or motor damage.

**▲ DANGER** The cable fasteners on this or any winch are not designed to hold rated loads. Always leave a minimum of five wraps of cable on the drum at the bottom layer to achieve a rated load.

8. Inspect the entire cable for weak or worn condition or kinking (short tight twist or curl) before each use.
9. When replacing the cable, always use a Powerwinch cable with the same winch rating and cable strength.
10. Never substitute rope for cable. Possible injury could occur.
11. Do not attempt to pull a load greater than the rated load of the winch.
12. Do not use the winch to hold or support the load once a job is complete or to permanently secure the load. Damage could occur to the winch or the load.

13. Never wrap the winch cable around the load. Use a recovery strap or chain to prevent the cable from kinking or fraying.
14. Always wear leather gloves when handling the cable. Steel cable can cause hand injuries.

**▲ CAUTION** After using the winch, always disconnect the power cord from the socket to avoid moisture collection in the socket and prevent the possibility of short circuiting.

15. Always block the vehicle wheels to help prevent the vehicle from rolling when pulling a load with the winch.
16. Do not operate the winch under the influence of drugs, alcohol, or medication.
17. After using the emergency hand crank, always remove the crank before restoring power. The crank will turn under power and could cause serious injury.

### Installation

#### MOUNTING

These winches can be mounted on a ball

## Specifications

Various load conditions will affect the winch performance. The line pull required for a specific application depends on the weight of the load, load surface, degree of incline between the winch and the load. The charts on this page is based on a single line pull and is only a guideline to aid in calculating pulling requirements.

### Approximate Rolling Load Capacities

% Incline	Model	Level Surface	5%	10%	20%	30%	50%	70%	100%
(° Incline)		0°	3°	6°	11°	17°	26°	35°	45°
Load (lbs)	QC1500/AP1500	15,000	10,005	7,530	5,250	3,915	2,790	2,295	1,935
	QC3500/AP3500	35,000	23,345	17,570	12,250	9,135	6,510	5,355	4,515
	QC2500	25,000	16,675	12,550	8,750	6,525	4,650	3,825	3,225
	QC4500	45,000	30,015	22,540	15,750	11,745	8,370	6,885	5,805

- A 10% incline (or 6°) is 1 ft. rise in 10 feet
- To convert pounds to kilos, divide by 2.2
- Capacity can be increased (almost doubled) by using a pulley block (Part Number P79043)

### Line Pulling Capacities and Minimum Ball Hitch Rating

Model	Single Line Pull	Double Line Pull	Trailer Classification	Trailer Coupling Designation	Ball Diameter
QC1500/AP1500	1,500 lb	N/A	Class 1	No. 1	1-7/8" (47.6 mm)
QC3500/AP3500	3,500 lb	6,500 lb	Class 2	No. 2	2" (50.8 mm)
QC2500	2,500 lb	5,000	Class 2	No. 2	2" (50.8 mm)
QC4500	4,500 lb	9,000 lb	Class 2	No. 2	2" (50.8 mm)

**⚠ WARNING** *Never use ball hitch rating below the recommended minimum or serious vehicle damage or personal injury could occur.*

### Winch Specifications

Model	Line Speed @ Capacity (FPM)	Gear Ratio	Voltage	Circuit Breaker	Unit Weight (lb)	Depth	Height	Width
QC1500/AP1500	15	270:1	12	30	23	10"	10"	8.5"
QC3500/AP3500	12	297:1	12	60	40	10"	10"	8.5"
QC2500	14	225:1	12	60	29	10"	10"	8.5"
QC4500	7	225:1	12	60	29	10"	10"	8.5"

hitch or in a truck bed. Below is a list of additional items and tools required, but not supplied that is needed to install the winch.

**TOOLS REQUIRED:**

- Electric drill and 13/32" drill bit
- 11/16" wrench
- 9/16" wrench

**MATERIAL REQUIRED (NOT INCLUDED):**

- Pull ties or electrical tape

**TRUCK BED MOUNTING MATERIALS ONLY**

- 1/4" steel plates (2)
- 3/8" Grade 5 bolts, lock washers and nuts (2) to mount the winch mounting plate to the winch. (Bolt length depends upon mounting location)
- 3/8" Grade 5 bolts, lock washers and nuts (4) to mount the winch mounting plate/ winch assembly to the truck bed. (Bolt length depends upon mounting location)

**BALL HITCH MOUNTING**

To mount the winch on a ball hitch, refer to Figure 1 follow the outlined procedures.

1. Securely attach the plate studs to the adapter plate using the hex nuts and lock washers supplied. Torque the plate studs to 25 in.lb. Make sure to match the hole locations on the adapter plate with the keyhole slots on the base of the winch.
2. Slide the adapter plate over the ball hitch.
3. Place the winch over the plate studs and slide the winch away from the ball hitch to lock the winch into place.

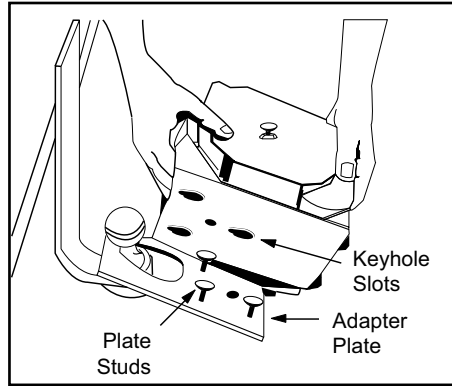

Figure 1 - Ball Hitch Mounting

**TRUCK BED MOUNTING**

Most truck beds are not made to support the pulling capacity of a winch. Therefore, the bed should be reinforced with a steel plate capable of withstanding the rating of the winch. Two 1/4" steel plates are recommended. Use the enclosed template as a guide to the drill the winch mounting holes. One plate is used for reinforcement under the bed and the other is used underneath the winch. To mount the winch in a truck bed, refer to Figure 2, use the enclosed mounting template and follow the outlined procedures.

1. Place the enclosed mounting template in the desired position in the truck bed and drill the hole labeled HOLE #1 and HOLE #2.
2. Drill an additional 4 holes **outside** of

the winch base area shown on the template to attach the winch mounting plate to the truck bed.

3. Mount the winch to the winch mounting plate using (2) 3/8" GRADE 5 bolts, lock washers and nuts.
4. Mount the winch with the winch mounting plate attached to the truck bed using (4) 3/8" GRADE 5 bolts, lock washers and nuts.

**WIRING HOOKUP**

Even though each model looks similar, each model has a specific wiring hookup. The procedures on the following page are broken into four separate sections.

**QC1500 WIRING HOOKUP**

To hookup the QC1500, refer to Figure 3 and follow the outlined procedures.

1. Insert the harness plug into the power socket on the winch.
2. Connect the battery clip on the **black** wire to the **negative (-)** battery post.

**⚠ WARNING** *Do not connect the battery clip on the red wire to the POSITIVE TERMINAL before connecting the clip on the black wire to prevent electrical arcing.*

3. Connect the battery clip on the **red** wire to the **positive (+)** battery post.

**Never attach the**

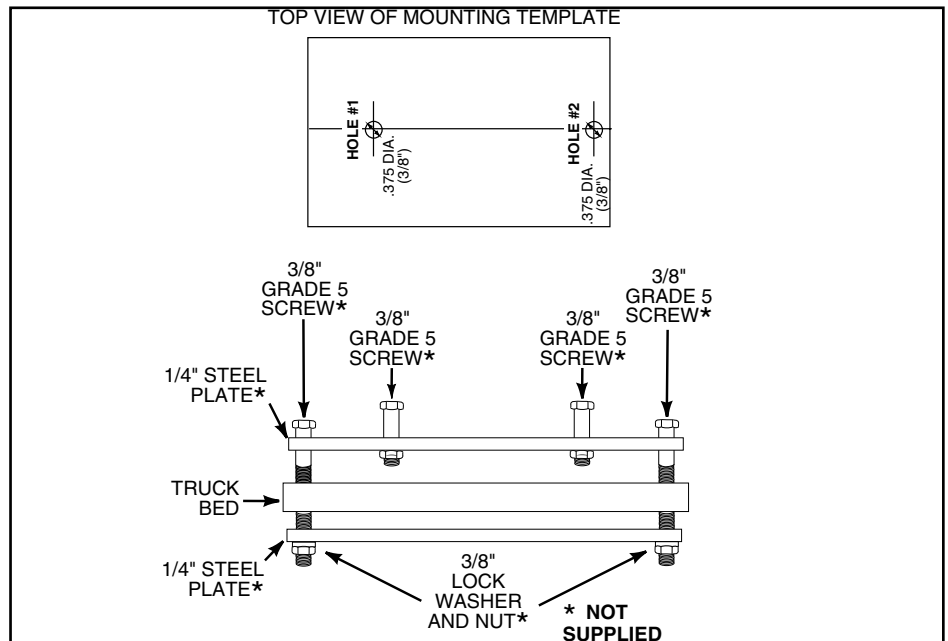

Figure 2 Truck Bed Mounting

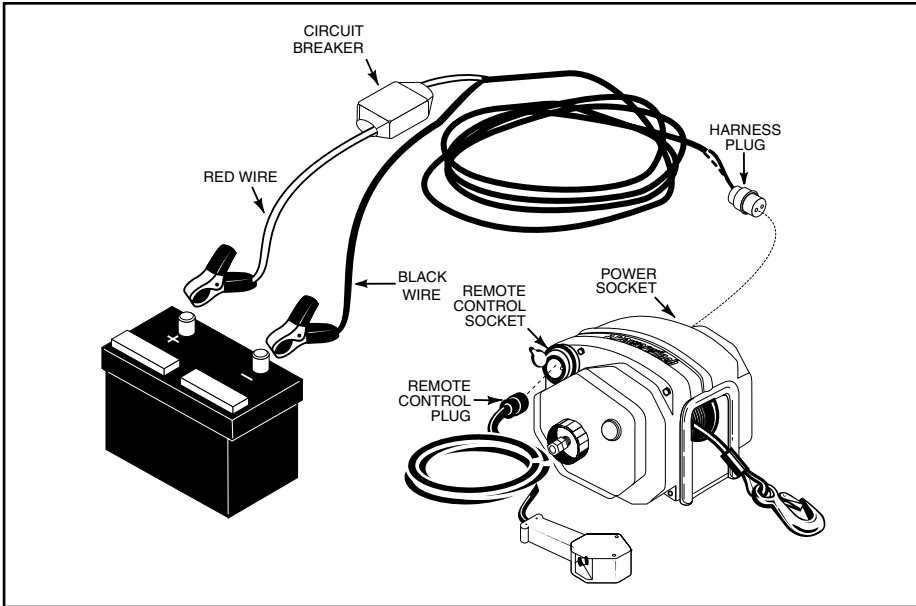

Figure 3 - QC1500 Wiring Hookup

**CAUTION** *red wire with the circuit breaker to the negative (-) or ground battery terminal. Incorrect wiring will short circuit and damage the circuit breaker and/or motor which could cause damage to the vehicle and winch.*

4. Plug the remote cord into the remote control socket.

**QC2500, QC3500 AND QC4500 WIRING HOOKUPS**

To hookup the QC2500, QC3500 and QC4500, refer to Figure 4 and follow the outlined procedures.

1. Insert the harness plug into the power socket on the winch.
2. Connect the battery clip on the **black** wire to the **negative (-)** battery post.

**WARNING** *Do not connect the battery clip on the red wire to the POSITIVE TERMINAL before connecting the clip on the black wire to prevent electrical arcing.*

3. Connect the battery clip on the **red** wire to the **positive (+)** battery post.

**CAUTION** *Never attach the red wire with the circuit breaker to the negative (-) or ground battery terminal. Incorrect wiring will short circuit and damage the circuit breaker and/or motor which could cause damage to the vehicle and winch.*

4. Plug the remote cord into the remote control socket.

cover into the plug base and slide the rubber boot firmly over the plug.

5. Run the **red** and **black** wires under or through the vehicle. Drill holes to feed the wires and be sure to protect the wires from damage by using grommets (not supplied). Worn wire insulation can cause short circuits. At 10" intervals, join the red and black wires together using electrical tape or wire wraps.
6. Attach the 5/16" ring terminal to the end of the black wire and crimp together.
7. Attach the black wire with the 5/16" ring terminal to the vehicle frame.

**WARNING** *Do not connect the positive wire before grounding the black wire to the vehicle frame to prevent electrical arcing.*

**AP1500 WIRING HOOKUP**

To hookup the AP1500, refer to Figure 5 and follow the outlined procedures.

1. Strip approximately 3/8" of insulation from each wire end.
2. Grasp one end of the red and black wires, insert the wires into rubber boot and the plug cover.
3. Attach the **red** wire to the **gold** terminal and attach the **black** wire to the **silver** terminal.
4. Firmly tighten the two screws that hold the wires in place. Screw the plug

8. Attach the 3/16" ring terminal to the end of the red wire and crimp together.
9. Connect the red wire with the 3/16" ring terminal to the circuit breaker.
10. Connect the circuit breaker to the battery terminal.

**CAUTION** *Never attach the red wire with the circuit breaker to the negative (-) or ground battery terminal. Incorrect wiring will short circuit and damage the circuit breaker and/or motor which could cause damage to the vehicle and winch.*

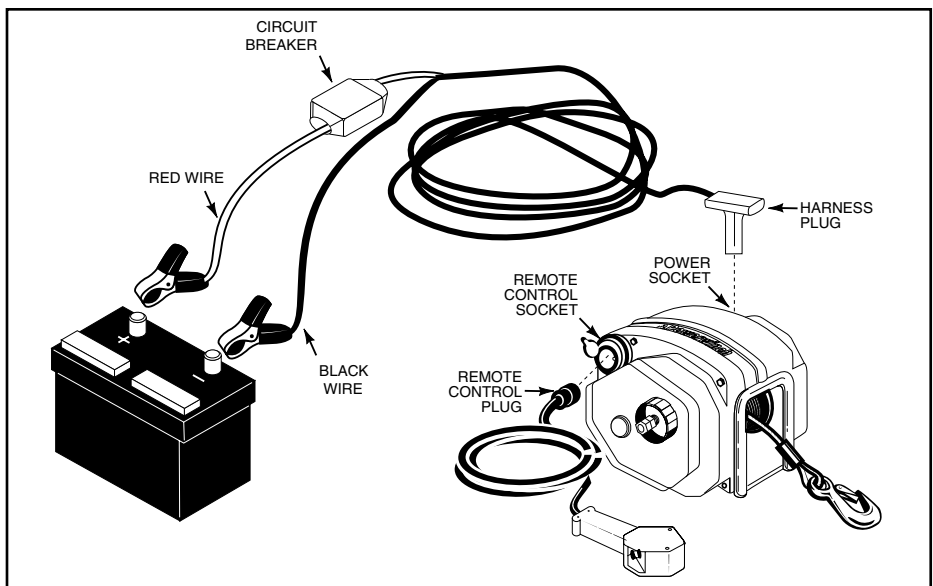

Figure 4 - QC2500, QC3500 and QC4500 Wiring Hookups

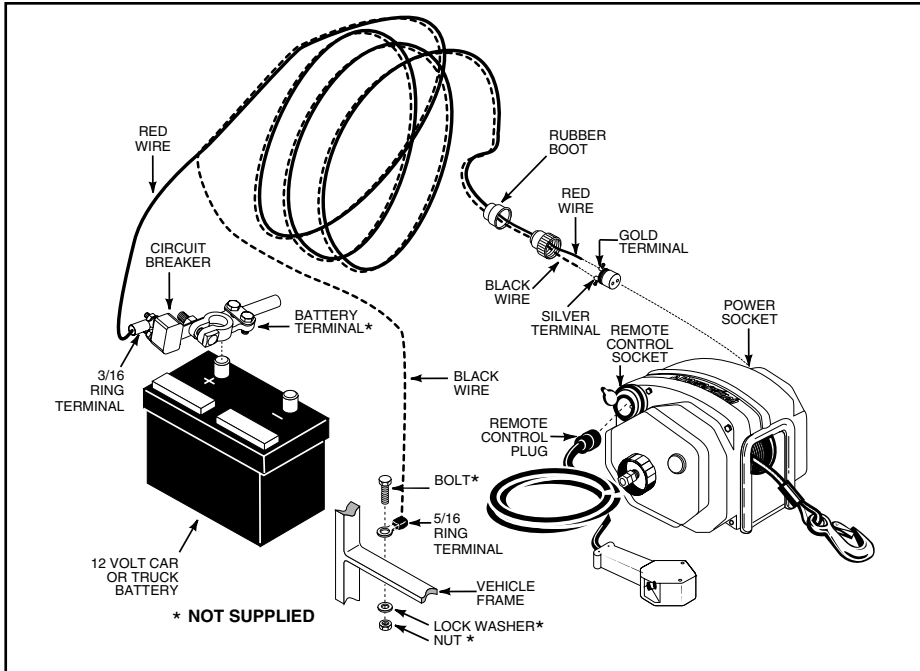

Figure 5 - AP1500 Wiring Hookup

or motor which could cause damage to the vehicle and winch.

11. Plug the remote cord into the remote control socket and insert the plug into the power socket on the winch.

**AP3500 WIRING HOOKUP**

To hookup the AP3500, refer to Figure 6 and follow the outlined procedures.

1. Strip approximately 3/8" of insulation from each wire end.
2. Remove the three screws on harness plug cover and remove the cover. Attach the red wire to the gold terminal and attach the black wire to the silver terminal on the harness plug.
4. Firmly tighten the two screws to hold the wires in place. Attach the harness plug cover with screws.
5. Run the red wire under or through the vehicle. Drill holes to feed the wires and be sure to protect the wires from damage by using grommets (not supplied). Worn wire insulation can cause short circuits.
7. Attach the 5/16" ring terminal to the end of the black wire and crimp together.
8. Attach the black wire with the 5/16"

ring terminal to the vehicle frame.

**WARNING** Do not connect the positive wire before grounding the black wire to the vehicle frame to prevent electrical arcing.

9. Attach the 3/16" ring terminal to the end of the red wire and crimp together.
10. Connect the red wire with the 3/16"

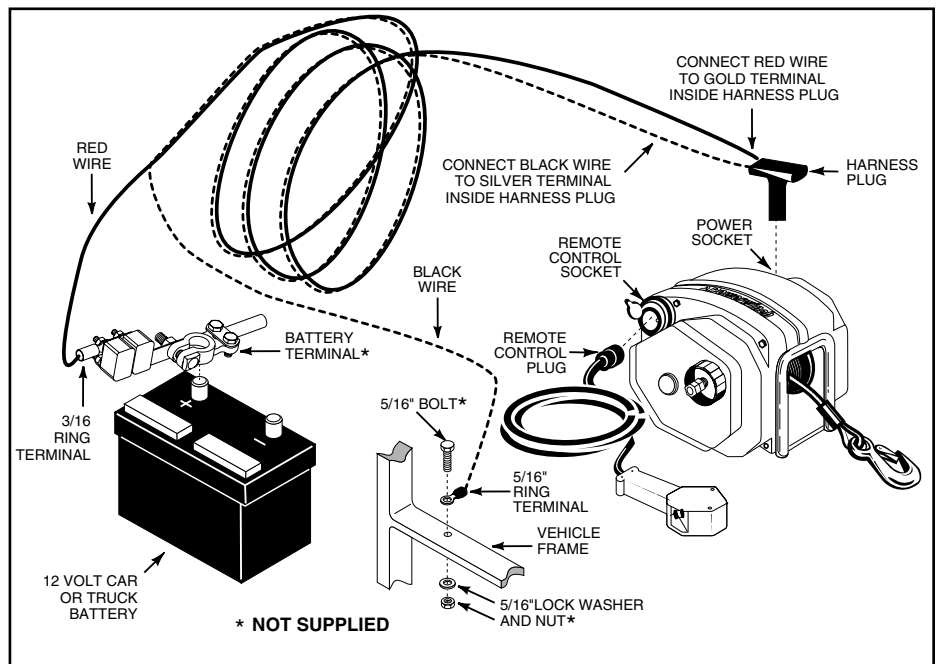

Figure 6 - AP3500 Wiring Hookup

ring terminal to the circuit breaker.

11. Connect the circuit breaker to the battery terminal.

**CAUTION** Never attach the red wire with the circuit breaker to the negative (-) or ground battery terminal. Incorrect wiring will short circuit and damage the circuit breaker and/or motor which could cause damage to the vehicle and winch.

12. Plug the remote cord into the remote control socket and insert the plug into the power socket on the winch.

**Operation**

There are two operating methods for the winch: automatic and manual. The following sections describe each mode of operation.

**WARNING** Always unplug the wiring harness to prevent accidental starting before attempting to install, service, relocate or perform any maintenance.

**AUTOMATIC MODE**

To use the winch in automatic mode, follow the procedures outlined below.

1. Set the vehicle's emergency brake and block the wheels.
2. Keep the vehicle standing still with the engine running and the transmission

in **NEUTRAL**.

**CAUTION** Never winch a load with the vehicle in "park." This could damage the vehicle's transmission.

- The clutch control knob on the side of the winch controls winch braking. Turn the knob fully counterclockwise. This releases the clutch (See Figure 7).

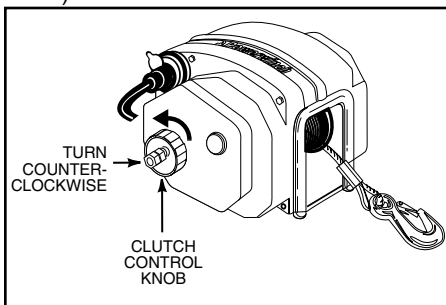

Figure 7 - Clutch And Brake Release

- Pull the cable out using the hook to the desired length.

**DANGER** The cable fasteners on this or any winch are not designed to hold rated loads. Always leave a minimum of five wraps of cable on the drum at the bottom layer to achieve a rated load.

- Turn the clutch control knob clockwise until tight. **DO NOT** overtighten the knob or clutch damage will occur (See Figure 8).

Figure 8 - Clutch and Brake Engagement

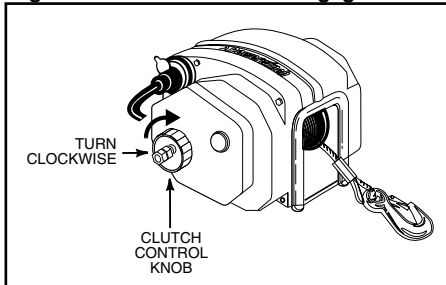

- Secure the load. Use a Recovery Strap (Part Number P77406) or a chain (properly load rated) to prevent the cable from twisting or fraying. Never wrap the winch cable around

the load (See Fig. 9).

Figure 9 - Cable Attachment

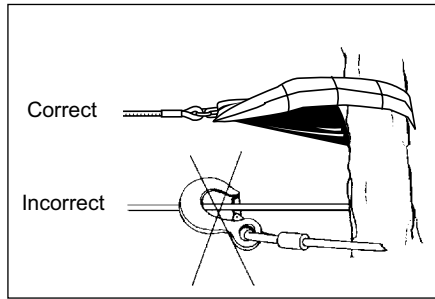

**NOTE:** Place a blanket over the cable to help prevent the cable from whipping, if the cable breaks.

- If winch stalls under load, accelerate the vehicle engine so that the winch can receive full power.

**CAUTION** Never jerk any object using vehicle power. This will cause winch damage.

**WARNING** Clear the area around and behind the vehicle of people, animals, and obstructing objects before winching. Personal injury could occur.

**WARNING** Always stand clear of the area behind and between the load or anchor point and the winch. If the cable breaks, serious personal injury could occur.

- Press the remote control button to winch in the load. The motor will idle for a few seconds after the button is released, allowing approximately one foot of cable to wind onto the drum.

**CAUTION** A minimum 12 inch clearance is required between the winch and the load to prevent the cable hook from being drawn into the winch drum.

**MANUAL MODE**

The emergency hand crank is used in manual mode. Manual mode should only be used when there is no power source i.e. dead battery. The emergency hand crank should never be used to help a running motor. To use the winch in manual mode, follow the outlined procedures .

- Turn the clutch control knob clockwise until tight. **DO NOT** overtighten the knob or clutch damage will occur (See Figure 10).
- Remove the outer nut shown in Figure 10 and place the emergency hand crank on the shaft.

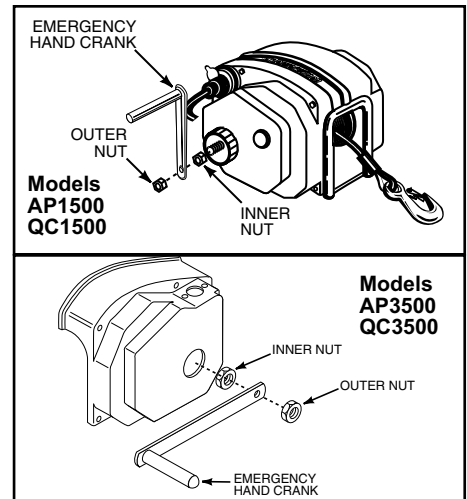

Figure 10 - Emergency Hand Crank

- Tighten the outer nut firmly against the hand crank.

After using the emergency hand crank, follow the procedures outlined below.

- Remove the outer nut shown in Figure 10 and remove the emergency hand crank off the shaft.
- Tighten the outer nut firmly against the inner nut.

**Maintenance**

**LUBRICATION FOR ALL MODELS**

Once a year, the cable should be lubricated with Whitmore's Wire Rope Spray, WD40 or a similar product. Spray the drum and the cable as the cable is being wound. Lubricate ALL gears with a lithium base grease once a year.

**LUBRICATION FOR MODELS QC2500, QC3500, QC4500 AND AP3500 ONLY**

**IMPORTANT:** Never grease the tri-matic roll-n-gage clutch control. Use a GOOD GRADE OF light oil only.

The Tri-Matic Roll-N-Gage Control is the heart of the winch. It controls loading, unloading and braking. To lubricate, refer to Figure 11 and follow the procedures outlined below.

- Remove the nut and unscrew the control knob. Remove the case on the control side and put the knob back on so that parts of the Roll-N-Gage Control will not slip off.

**CAUTION** Extreme caution must be taken to avoid getting oil on the clutch lining because this may cause slippage.

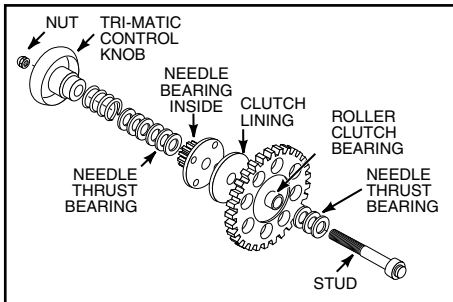

Figure 11 - Tri-Matic Lubrication

- Using a good grade of light oil, lubricate the stud, the needle thrust bearings (2), roller clutch bearing (1) and needle bearing (1).

### MOTOR REPLACEMENT

To replace the motor, refer to Figure 12 and follow the outlined procedures.

**⚠ WARNING** Always unplug the wiring harness to prevent accidental starting before attempting to install, service, relocate or perform any maintenance.

- Unplug the wiring harness, remove the two cover rods and the four cover screws.
- Gently hand turn the gears of the old motor back and forth to notice the backlash (.005). The gears of the new motor should have the same degree of play.
- Loosen the screws on the motor bands and remove the bands.
- Disconnect the motor leads, pay attention to the connections and remove the motor.
- Put the new motor in place, taking care to see that the gears mesh properly.
- Fasten the motor band and connect the new motor leads to the appropriate lead connections.
- Check the motor for correct backlash. The gears should not be too tight or too loose. Adjust the backlash by increasing or decreasing the thickness of the shims between the motor and motor support rods.
- Install the cover, two cover rods and the four cover screws and connect the wiring harness.

### CABLE REPLACEMENT

To replace the cable, follow the outlined procedures. Use an exact replacement cable Powerwinch. The winch rating and cable strength are carefully matched. Never replace the cable with rope.

**⚠ WARNING** Always unplug the wiring harness to prevent accidental starting before attempting to install, service, relocate or perform any maintenance.

- Power-out the cable using the remote control device and unplug the wiring harness.
- Remove the two cover rods and the four cover screws (See Figure 12).

Figure 12 - Motor Replacement

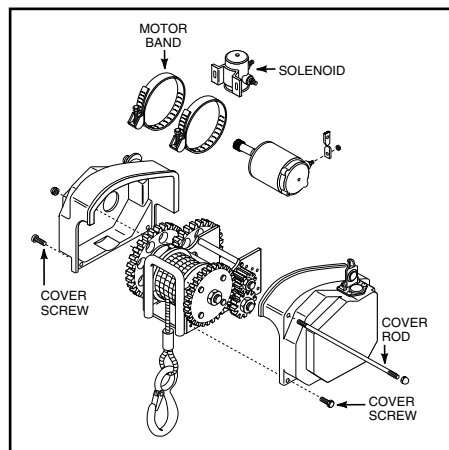

- Cut the old cable approximately 2" from the drum and push the remaining cable and fastener through the drum to remove (See Figure 13).
- Insert the new cable into the drum shaft hole at the end opposite the counterbored end. Draw the cable through the hole and out the counterbored side of the shaft.
- Push the cable through the fastener until the cable is flush with the end of the fastener.
- Crimp the fastener onto the cable and pull the cable through the drum shaft until the fastener seats inside the counterbore.

Figure 13 - Cable Replacement

- Install the cover, two cover rods and

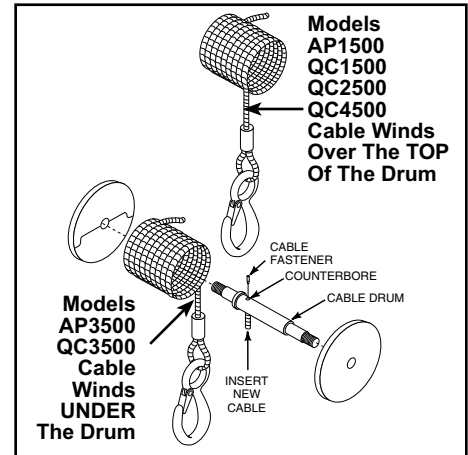

the four cover screws and connect the wiring harness.

- Power-in the cable with a light load to help wind the cable straight into the drum.

**⚠ DANGER** The cable fasteners on this or any winch are not designed to hold rated loads. Always leave a minimum of five wraps of cable on the drum at the bottom layer to achieve a rated load.

### LEVELWIND PLATE

When powering-in the cable, the motor will continue to run for a few seconds after releasing the button on the remote control device, especially without a load. Be sure to allow for this. Do not let the cable hook go into the winch and bend the level wind plate. When winding the cable onto the drum with no load, keep the cable taut (tight) going into the drum.

### STORAGE

The winch cable must be lubricated before storing. Lubricate the cable with Whitmore's Wire Rope Spray, WD40 or a similar product. Spray the drum and the cable as the cable is being wound.

### Technical Service

For information regarding the operation, repair or replacement parts for this product, please call 1-800-243-3097 for assistance. Please provide the following information:

- Model number
- Serial number
- Part number and description

## Troubleshooting Chart

Symptom	Possible Cause(s)	Corrective Action
Winch will not operate.	1. Disconnected or bad wiring or bad circuit breakers.	a. Start checking the wiring at the battery. Bypass the circuit breakers and test the winch. If the winch operates, replace the circuit breakers.  b. Check the wiring insulation for worn or bare spots that may be causing a short.  c. Check all connections for tightness.
	2. Bad plug.	a. Check the male connection at the end of the wiring kit by using probe light across the two prongs inside the plug. If the light illuminates, the wiring is correct.  b. Remove the two cover connecting screws and rods (See Figure 3) from the cover containing the female socket. Plug the male socket into the female socket. Use a probe light across the two connections on the underside of the female socket. Replace the appropriate socket if the light does not illuminate. If the light illuminates, check the switch and/or motor.
	3. Bad switch or motor.	Check the switch terminals with a probe light. Close the switch with the probe across the terminals. If the light comes on, replace the motor. If the light does not come on, replace the switch.
Clutch does not hold.	Clutch knob too loose.	Tighten the clutch knob.
	Worn gears or clutch lining	Replace gears or lining.

### LIMITED WARRANTY

A. This Limited Warranty is given by the Powerwinch Division of the Scott Fetzer Company (the "Company") to the original purchaser (the "Purchaser") of a Powerwinch Product (the "Product") specified in this manual. This Limited Warranty is not transferable to any other party.

B. Responsibilities of the Company under this Limited Warranty:

1. Repair or replace (at the discretion of the Company) any part or parts of the Product found by the Company to be defective within a two (2) year period from the date of purchase.
2. The Company will pay the transportation charge for shipment back to the Purchaser of any Product received for legitimate Warranty repair.

C. Responsibilities of the Purchaser under this Limited Warranty:

1. Complete (fully and accurately) and return to the Company, the Warranty card included in the box. Otherwise, Purchaser will have to show dated proof of purchase to qualify for service under the provisions of the Limited Warranty.
2. Promptly notify the Seller or the Company of any claim hereunder.
3. At the Option of the Company, return the Product to the Company for inspection. Authorization must be given prior to any Product return. Call the Company at 1-800-243-3097 or write the Company at 2145 West 6th Ave, Broomfield, CO 80020, for authorization and complete instructions on how to return the Product directly to the Company.
4. Use reasonable care in maintenance, operation, use and storage of the Product in accordance with the instructions contained in the Owner's Manual.
5. Have Warranty work performed by a dealer or representative approved by the Company.
6. Except as noted in B.2., transportation charges are the responsibility of the Purchaser.

D. This Limited Warranty covers:

1. Defects in workmanship or materials.
2. Any part or parts of the Product sold or manufactured by the Company.

E. This Limited Warranty does not cover:

1. Any failure that results from improper installation of the Product.
2. Any failure that results from accident, Purchaser's abuse, neglect, modification, improper maintenance, or failure to operate and use the Product in accordance with the instructions provided in the Owner's Manual supplied with the Product.
3. Any cable replacement other than a break. Cable is a wear item and will fray and twist during normal use.

F. There is no other express warranty. Implied warranties, including those of merchantability and fitness for a particular purpose, are limited to one (1) year from date of purchase. This is the exclusive remedy and any liability for any and all incidental or consequential damages or expenses whatsoever is excluded. Some states do not allow limitations on how long an implied warranty lasts, or do not allow exclusion or limitation of incidental or consequential damages, the above limitations may not apply to you.

This Limited Warranty gives you specific legal rights, and you may also have other rights which vary from state to state.

Powerwinch reserves the right to alter specifications on any product without notice.

All rights reserved. This publication or parts thereof may not be reproduced in any form without written permission.