

### MOTORIZED FOLDING CAMPER WINCH With 1200lb Lift Capacity

*The 12 Volt Motorized Folding Camper Winch is used to raise and lower folding campers with the touch of the switch, eliminating hand cranking.*

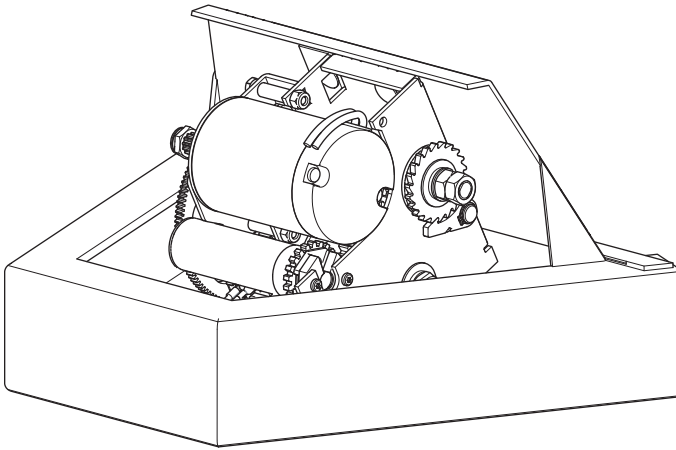

This manual also contains instructions for mounting the Universal Replacement Cover.

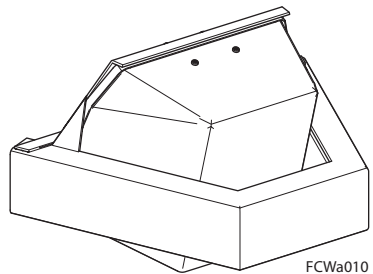

FCWa010



**Thoroughly read the manual furnished with this product and be familiar with the controls. Do not allow individuals to operate the winch without understanding the safe operation and procedures for the equipment.**

# TABLE OF CONTENTS

<b>Safety Information</b> .....	<b>3</b>
<b>Winch Installation</b> .....	<b>4</b>
Electrical Setup .....	4
Setting the Cable.....	5
Setting the Limit Switches .....	5
Setting the Lower Limit Switch .....	6
Setting the Upper Limit Switch .....	6
<b>Mounting the Universal Replacement Cover</b> .....	<b>7</b>
Mounting the Switch in the Cover.....	8
<b>Operating the Winch</b> .....	<b>9</b>
Manual Override.....	9
<b>Maintenance</b> .....	<b>10</b>
Cable.....	10
Electrical .....	10
Troubleshooting Guide .....	11
<b>Replacement Parts List</b> .....	<b>12</b>
<b>Warranty</b> .....	<b>14</b>

## SAFETY INFORMATION

The following Safety Precautions Must be Followed at ALL Times. Failure to follow the warnings and cautions in this manual could result in serious injury and/or property damage.



### **WARNING**

ALWAYS unplug the wiring harness before attempting to install, relocate, service or perform maintenance on the winch.



### **WARNING**

NEVER use the winch to lift or move people or animals.



### **WARNING**

NEVER use the winch to exclusively hold, support or permanently secure the top. Use separate brace(s) to support the camper top when raised.



### **WARNING**

NEVER extend the top beyond the visual height indicators on the camper.



### **WARNING**

ALWAYS stand away from the winch during operation.

ALWAYS keep objects, people and animals away from the camper and camper top when operating the winch. Serious injury could occur if the cable breaks.



### **WARNING**

NEVER wear loose fitting clothes, scarves, ties or jewelry when operating the winch. Loose clothing can become caught in moving parts.



### **CAUTION**

ALWAYS keep hands clear of the cable spool (drum area).



### **CAUTION**

ALWAYS wear leather gloves when handling the cable. Steel cable can cause serious damage to hands.



### **CAUTION**

Remove all tools used for manual override operation before operating the winch with the electrical power.



### **NOTICE**

Do not use this winch on any campers with a top (including accessories) that exceeds 1200 pounds in weight.



### **NOTICE**

Do not lift the camper top if there is cargo such as luggage or bicycles on the camper top. The extra load can overload the winch and cause damage that may void the warranty.



### **NOTICE**

The winch has a 5-minute duty cycle. Wait at least 5 minutes between each lifting cycle. Running the winch continuously will damage the motor and gears and void the warranty.

## CALIFORNIA PROPOSITION 65



### **WARNING**

This product contains chemicals known to the state of California to cause cancer or birth defects or other reproductive harm. California's Proposition 65 requires this warning to be given to customers in the state of California.

---

WINCH INSTALLATION

1. Park the camper on a hard level surface. Place wheel chocks under the wheels to prevent the camper from moving.
2. Make sure the camper top is lowered completely and there is no tension on the winch cable. Remove the cable from the existing winch.
3. Remove the existing winch. **SAVE** the fasteners to install the new winch.

**NOTE:** If there is not an existing winch, the installer must furnish three (3) each of 3/8-16 x 1 carriage bolts, lock washers and nuts.

4. Using the fasteners from step 3 and attach the new winch to the trailer frame. Ensure that the winch is centered and vertical. Torque nuts to 20 ft-lbs.

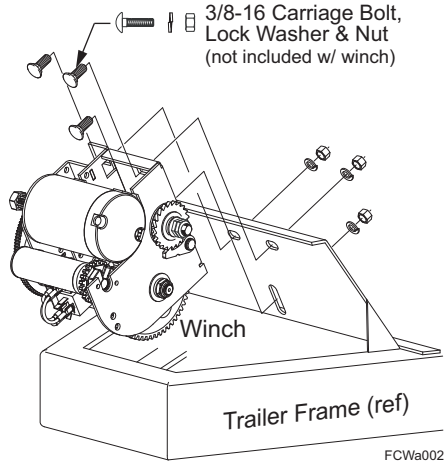

ELECTRICAL SETUP

(Refer to the wiring diagram on page 10.)

1. Determine the mounting location of the switch. The position should provide easy access but not in a position where the switch can be accidentally damaged.
  - The cable is 12" from the winch to the switch.
  - There is 36" of cable from the winch to the battery connection.
  - Before continuing, lay the cable out to be sure that the switch will mount without straining the wires allowing a minimum of 1"-2" of slack. The wires must be mounted to avoid moving parts such as the gear train and cable.

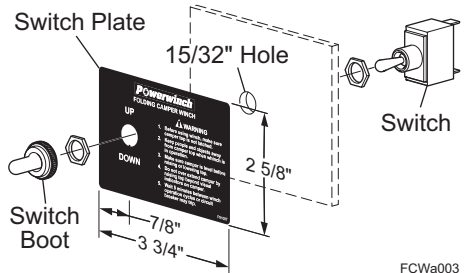

2. Drill a 15/32" hole.
3. Clean and dry the surface then peel off the paper backing from the switch plate and adhere the switch plate over the hole. The hole in the plate must align with the hole drilled in step 2.
4. Mount the switch using the supplied jamb nuts and the rubber switch boot. Orient the switch so that the notch in the switch aligns with the tab in the hole of the switch plate.
5. Route the battery wires to the battery.
6. Attach the RED wire with the 40-amp circuit breaker to the POSITIVE (+) terminal of the battery; attach the BLACK wire to the NEGATIVE (-) terminal.
7. Route wire cables away from any moving parts such as the gear train and cable and secure to the frame using nylon ties or equivalent.

## SETTING THE CABLE

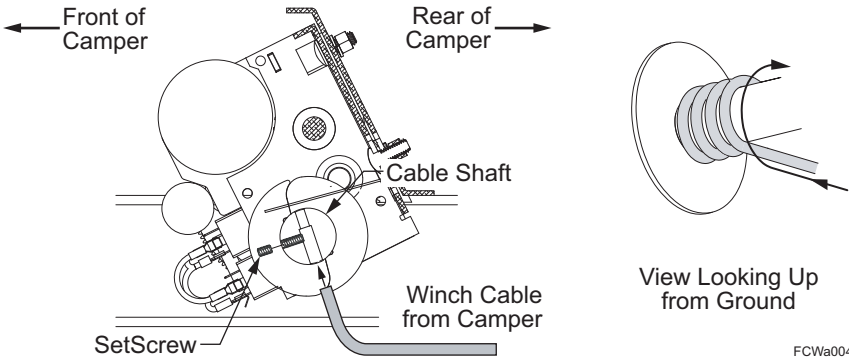

FCWa004

1. Using the switch, move the cable shaft until the cable hole and the setscrew are accessible.
2. Insert the cable into the large hole of the drum shaft.
3. Using a 1/8" allen wrench, tighten the setscrew to hold the cable in shaft.
4. Begin wrapping the cable onto the shaft by holding the switch in the "UP" position. The cable must have a minimum of three (3) complete wraps around the shaft.
5. Check the cable, there must be no slack in the cable. If there is slack, use the up switch to continue winding the cable on the drum until the slack is gone.

**NOTE:** The cable is slack if there is perceptible sag or waviness between the winch and other end of the cable.

## SETTING THE LIMIT SWITCHES

The limit switches turn off the winch when the camper top is closed (lower limit switch) and when the top is fully extended (upper limit switch).

**NOTICE** Failure to set the lower limit switch can cause the top to not close completely (switch shuts off early) or cause the motor to run after the top is down causing an overload for the motor. Both conditions can result in damage to the winch and/or camper and will void the warranty.

**NOTICE** The upper limit switch shuts the winch off when the camper top is raised to the height recommended by the camper manufacturer. Failure to set the upper limit switch can cause the top to not extend completely (switch shuts off early) or cause the top to be overextended. Both conditions can result in personal injury and/or damage to the winch and camper.

**NOTICE** The winch has a 5-minute duty cycle. Wait at least 5 minutes between each lifting cycle. Running the winch continuously will damage the motor and gears.

**NOTE:** On early units, the limit switches are accessed from below the frame. Newer units are accessed from the top as shown on the next page. The procedure is same for either position.

**NOTE:** The limit switches are not pre-set before shipping. During setup, the switch adjustment screws may initially require several complete turns (50 to 100) before the settings are obvious and can be fine-tuned for a particular installation.

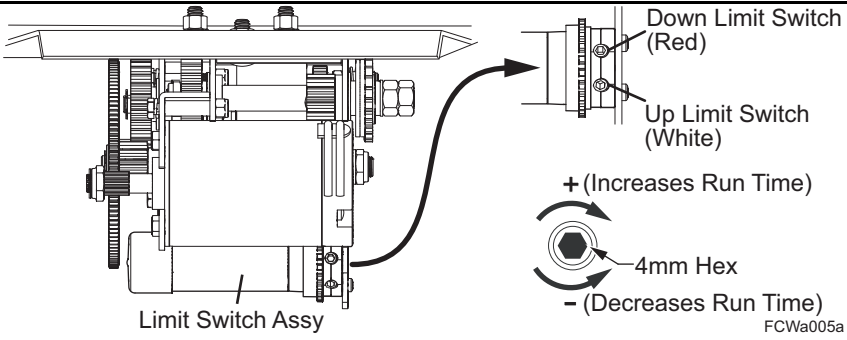

*Setting the Lower Limit Switch*

After attaching and winding the cable as described previously (page 5), it is necessary to set the lower limit switch.

1. Locate the RED down limit switch.
2. Using a 4mm allen wrench, turn the screw clockwise to increase the time the motor runs. Turn the screw counterclockwise to decrease the motor run time.
3. Test the setting:
  - Make sure that the latches for the camper top are released.
  - Use the winch switch and raise the camper top 10"-12".
  - Use the winch switch to lower the camper top.
  - If the top does not close completely before the motor stops, the limit switch is prematurely shutting off the motor. Repeat steps 1 through 3 to increase the motor run time
  - If the motor continues to run after the top is down, the limit switch is not shutting off the motor soon enough. Repeat steps 1 through 3 to decrease the motor run time.

*Setting the Upper Limit Switch*

1. Raise the camper top to the maximum height recommended by the camper manufacturer. There is generally a cord or other visual indicator to indicate when the top is at the correct height.
2. Use a brace to support the camper top while adjusting the winch.
3. Locate the WHITE up limit switch.
4. Using a 4mm allen wrench, turn the screw clockwise to increase the time the motor runs. Turn the screw counterclockwise to decrease the motor run time.
5. Test the setting:
  - Remove the support brace from step 2.
  - Use the winch switch and lower the camper top 10"-12".
  - Use the winch switch to raise the camper top.
  - If the camper top stops below the recommended height, the limit switch is prematurely shutting off the motor. Repeat steps 1 through 5 increase the motor run time.
  - If the motor continues to run after the camper top is fully raised, the switch is not shutting off the motor soon enough. Repeat steps 1 through 5 to reduce the motor run time.

## MOUNTING THE **UNIVERSAL REPLACEMENT COVER**

The cover assembly for the Powerwinch Motorized Folding Camper Winch is provided for aftermarket installations. The cover is designed to fit most general applications but may not fit all camper styles. Many camper manufacturers also offer cover options and may install their own for OEM applications.

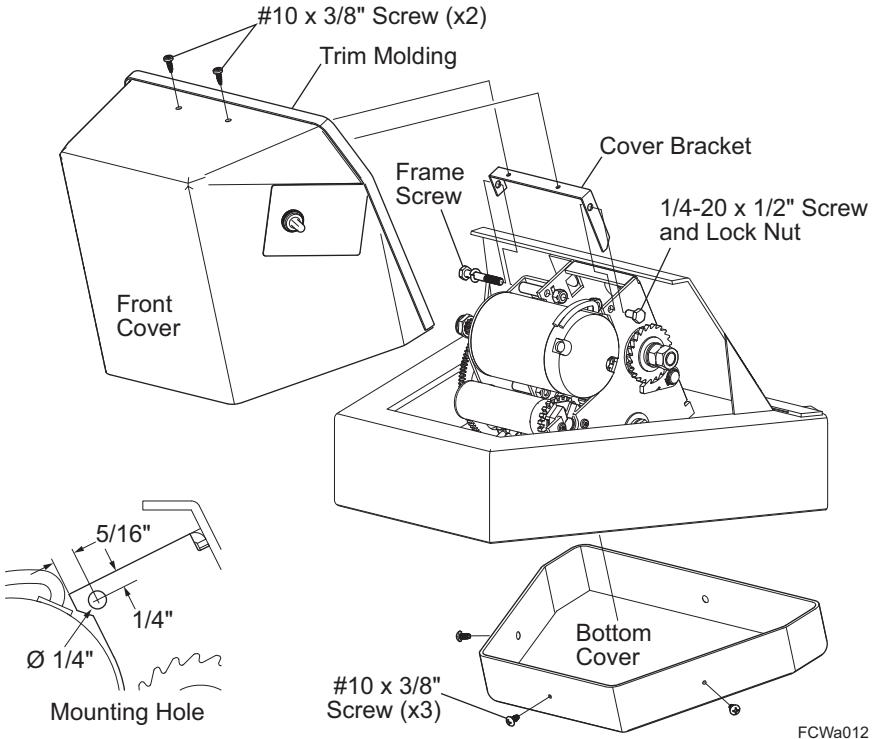

FCWa012

1. Install and adjust the winch according to the instructions in this manual.
2. Inspect the winch frame. On early units, it will be necessary for the installer to drill a 1/4" mounting hole for the cover bracket.
  - 2.1. Use the dimensions shown above.
  - 2.2. After drilling, clean and deburr hole.
  - 2.3. Thoroughly clean any debris and shavings from the winch.
3. Remove the frame screw. Keep track of the washer, spacer and nut.
4. Attach the cover bracket using the frame screw, washer, spacer and nut.
5. On the opposite side, attach the bracket using a 1/4-20 x 1/2" screw and lock nut.
6. If installing the switch in the cover, go to page 8. After installing the switch, continue with step 7.
7. Press the trim molding onto the back edge of the front cover.
8. Gently press the cover between the bracket and the upper lip of the mounting plate. Align the holes in the cover with the top holes in the mounting bracket.

9. Secure the cover to the bracket using two (2) #10 x 1/2 self-threading screws.
10. Check that the wire harnesses are routed away from any moving parts such as the gear train and cable and secure to the frame using nylon ties or equivalent.
11. Place the bottom cover on the bottom of the top cover and align the three (3) attachment holes.
12. Attach the bottom cover using three (3) #10 x 3/8 self-tapping screws. Use care to not over tighten the screws. Over tightening can cause the plastic to strip out. *Tip: Install the front screw first then install the two side screws.*
13. Check that all fasteners and wire cables are secure then attach the winch power cables to the battery. The RED wire with the 50 amp circuit breaker goes to the POSITIVE (+) terminal of the battery/ the BLACK wire to the NEGATIVE (-) terminal.

**MOUNTING THE SWITCH IN THE COVER**

These directions are if the switch is to be mounted in the cover if there is not a suitable frame location.

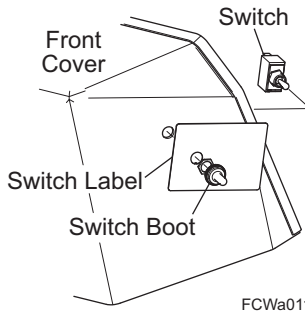

1. Locate the mounting hole in the right side of the top cover.
2. Clean and dry the surface then peel off the paper backing from the switch label and adhere switch plate over the hole. The hole in the plate must align with the hole in the cover.
3. Set the cover next to the winch so that the switch wires can reach the hole in the cover.
4. Mount the switch using the supplied jamb nuts and the rubber switch boot. Orient the switch so that the notch in the switch aligns with the tab in the hole of the switch plate.
5. Connect the switch wires use the wiring diagram on page 10.
6. Return to step 7 on the previous page.



## OPERATING THE WINCH

**NOTICE** The camper must be on a hard surface and leveled before raising or lowering the top.

**NOTICE** Make sure that the travel latches for the camper top ARE RELEASED before operating the winch to raise the camper top.

**NOTICE** The winch has a 5-minute duty cycle. Wait at least 5 minutes between each lifting cycle. Running the winch continuously will damage the motor and gears.

Press Up and Hold to  
RAISE the camper top



Press Down and Hold to  
LOWER the camper top

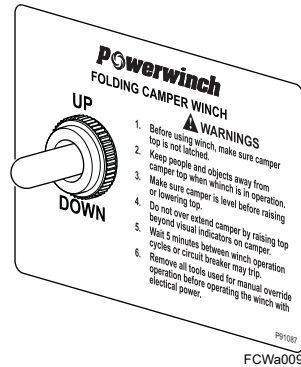

## MANUAL OVERRIDE

In the case of a power failure, (battery is discharged or missing), the winch can be operated manually to raise or lower the camper top.

1. Locate the 3/4" manual drive nut located at the end of the motor drive shaft.
2. Using a 3/4" socket, turn the bolt clockwise to lower the top; counterclockwise to raise the top.

**NOTICE** If using an electric driver (i.e. drill) for the socket, use care to not overextend the top when raising or overwind when lowering the top. Over winding can cause damage to the winch motor and gears.

3/4" Override Nut  
To Lower: Turn Clockwise  
To Raise: Turn Counterclockwise

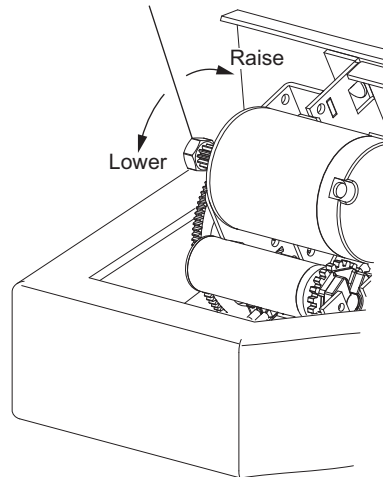

FCWa006

**CAUTION** Remove all tools used for manual override operation before operating the winch with the electrical power.

MAINTENANCE



**WARNING**

Always disconnect power to the winch before attempting to install, service or perform any maintenance on the unit.

*Cable*

- Periodically inspect the cable for kinks, cuts, or breaks. Immediately replace the cable if any damage is found. Replacement cables are available from the camper manufacturer.
- Lubricate the cable with 30 weight motor oil a minimum of once a year.

*Electrical*

- Periodically check the wiring for cuts, breaks and corrosion. Replace any broken wires. Clean any corrosion found on the electrical connections. Tighten any loose connections.

**WIRING DIAGRAM**

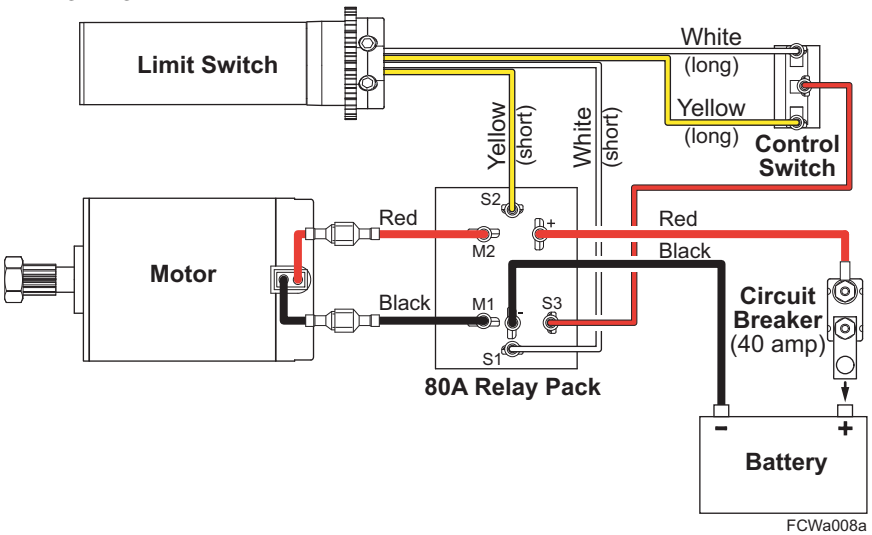

**NOTE:** On early units, the Yellow and White wires from the limit switch may be reversed. If replacing the relay, ensure that the wires go to the same terminals on the new relay as they were positioned on the old relay. If replacing the limit switch, connect the color wires as shown.

TROUBLESHOOTING GUIDE

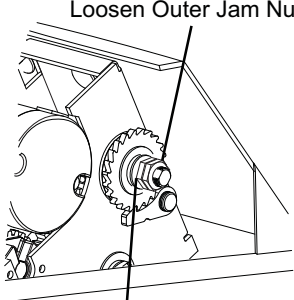
WINCH DOES NOT OPERATE		
<p>A. Confirm power to winch</p> <ol style="list-style-type: none"> <li>1. Check battery is fully charged.</li> <li>2. Confirm connections are for tight &amp; clean.</li> <li>3. Check if wires are worn or bare that may cause shorts.</li> </ol>		Correct as required.
<p>B. Check circuit breaker at battery</p> <p>Bypass circuit breaker and test winch. Does the winch run?</p> <p><b>⚠ CAUTION</b> Do not operate the winch without the circuit breaker. Removing the CB from the circuit is <b>ONLY</b> for testing.</p>	YES	If winch runs, circuit breaker is bad, replace.
	NO	Reconnect circuit breaker.
CAMPER TOP OVER OR UNDER EXTENDS		
<p>A. <u>Lower Limit Switch:</u> If the motor continues to run after the top is down; or, the motor stops before the top is down.</p>	The lower limit switch is set incorrectly. Refer to "Setting the Lower Limit Switch" on page 6.	
<p>B. <u>Upper Limit Switch:</u> If the motor continues to run after the camper top is fully raised; or, the top is not raised high enough before the motor shuts off.</p>	The upper limit switch is set incorrectly. Refer to "Setting the Upper Limit Switch" on page 6.	
CAMPER TOP LOWERS WITHOUT MOTOR		
<ol style="list-style-type: none"> <li>1. The folding camper winch uses a clutch to maintain tension in the drive gears. If the top slowly slips down, it will be necessary to tighten the clutch.</li> <li>2. Locate the clutch on the right side of the winch.</li> <li>3. Loosen the jam nut.</li> <li>4. Tighten the inner nut approximately 1/8 of a turn.</li> <li>5. Tighten the outer jam nut.</li> <li>6. Retest and repeat as necessary.</li> </ol>	 <p style="text-align: center;">Loosen Outer Jam Nut</p> <p style="text-align: center;">Tighten Inner Nut</p> <p style="text-align: right;">FCWa007</p>	

REPLACEMENT PARTS LIST

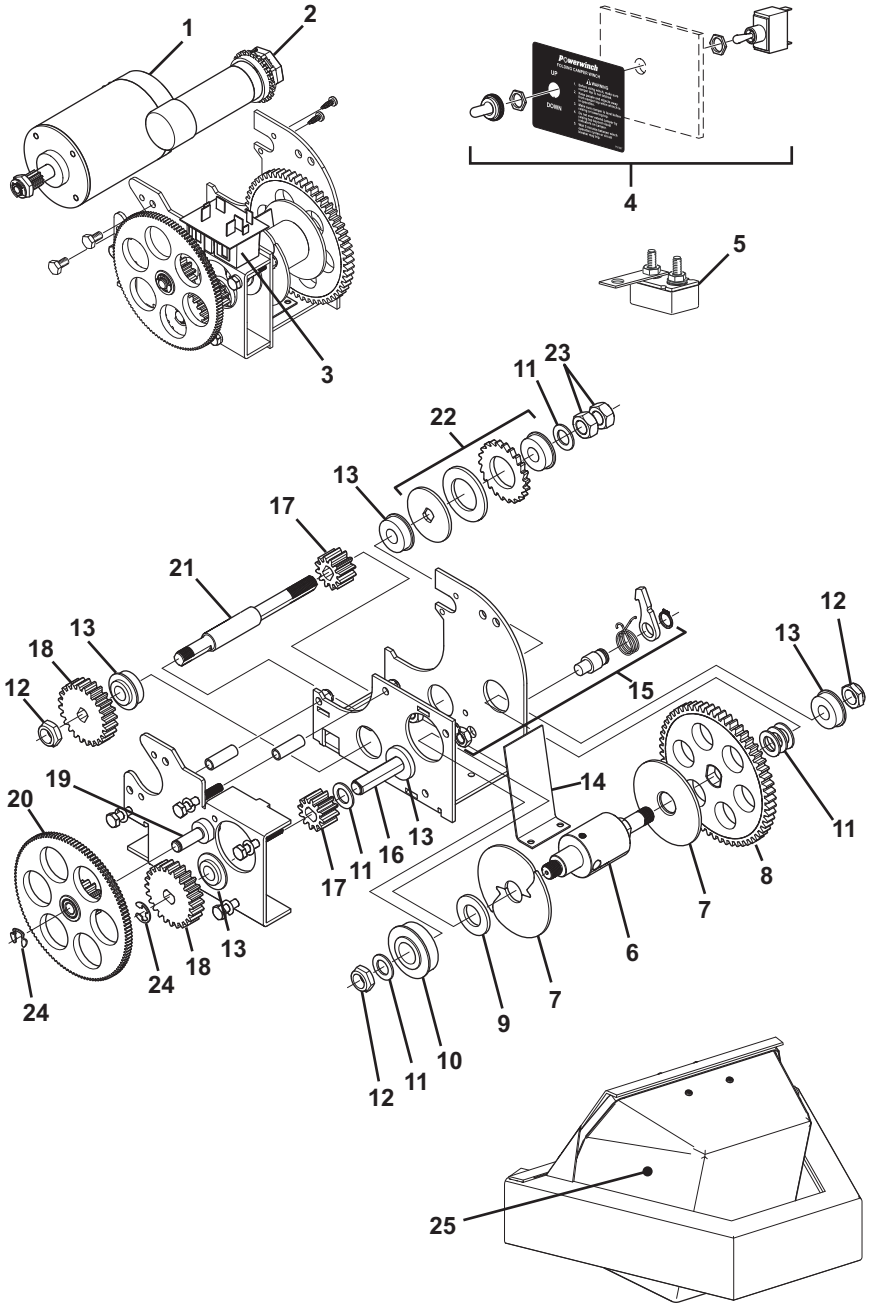

FCWa501

<i>Item</i>	<i>Part Number</i>	<i>Description</i>	<i>Notes</i>
1	R001749	Motor Assembly	1,2
2	R001750	Limit Switch Assembly	2
3	R001751	Relay Assembly	2
4	R001752	Switch Kit	
5	P7832300AJ	Circuit Breaker, 40A	
6	P9107400AJ	Cable Shaft	
7	R001753	Flange Kit	
8	P7170500AJ	Gear, 57T	
9	P7182900AJ	Washer, .75" I.D.	
10	P7165100AJ	Bearing, .75" I.D.	
11	P7182200AJ	Washer, .5" I.D.	pkg of 6
12	P7973800AJ	Jamb Lock Nut, 1/2-20	pkg of 3
13	P7160700AJ	Bearing, .5" I.D.	
14	P3005300AJ	Level Wind Plate	2
15	R001754	Pawl Kit	2
16	P9107200AJ	Shaft, Stage 1	
17	R001755	Pinion Gear, 12T	
18	R001756	Gear, 24T	2
19	R001757	Stud, Combo Gear	2
20	R001758	Gear, Combo, 120T/12T	2
21	P9108400AJ	Shaft, Stage 2	
22	R001759	Clutch and Gear Kit	
23	P9108400AJ	Nut, Jamb, 1/2-20	pkg of 2
24	P3003800AJ	Retaining Ring Kit, Assorted	pkg of 3
25	R001760	Cover Kit	2

- Notes:** 1. Motor includes gear and override nut.  
2. Fasteners are included with kit.

## WARRANTY

Scott Fetzer Electrical Group (hereafter referred to as SFEG) warrants to the FIRST retail Purchaser that the Powerwinch Product described in this manual is free of defects in material and workmanship within the terms and conditions as set forth below. SFEG's obligation under this warranty is limited to the repair or replacement with new or refurbished unit, at SFEG's option, of any defective component within the stated warranty period. THIS WARRANTY IS NOT TRANSFERABLE.

### **1. DURATION**

1.1. 1 year on parts.

1.2. SFEG will pay the transportation charges for return shipment to the purchaser of any product received for legitimate warranty repair.

Warranty duration is not extended by the length of time the product is not in use or the time that the purchaser is deprived the use of the product. The duration of coverage is determined by the date of the original product purchase, not the date of repairs.

### **2. WHAT IS COVERED UNDER THIS WARRANTY**

Defects in the manufacturer's material and workmanship of product under normal use, and which occur within the duration of the warranty period.

### **3. WHAT IS NOT COVERED UNDER THIS WARRANTY**

3.1. Improper installation and/or any consequent damage or failure that results from improper installation of the product.

3.2. Normal wear.

3.3. Conditions that are not related to the material or workmanship of the product: including any failure that results from an accident, wind, rain, or other acts of God.

3.4. Purchaser's abuse, including but not limited to neglect; failure to operate, use or maintain the product in accordance with the instructions provided with the product. 3.5. Any component not sold or manufactured by SFEG.

3.6. Any failure that results from the use of another manufacturer's product with a SFEG product that is not specifically approved by SFEG.

3.7. Any incidental, indirect, or consequential loss, damage or expense that may result from any defect, failure or malfunction of the product.

3.8. The removal or alteration of any product component or device. In the event of such removal or alteration, this warranty is void.

3.9. Any expense related to delivery or pick-up of product to/from the service dealer.

### **4. RESPONSIBILITIES OF THE PURCHASER**

IN ORDER FOR THE WARRANTY TO BE HONORED, THE PURCHASER MUST HAVE PROOF OF PURCHASE. FAILURE TO PROVIDE THE REQUIRED DOCUMENTATION MAY DELAY OR VOID ANY WARRANTY CLAIM.

4.1. Retain dated proof of purchase for the product, and provide it as requested.

4.2. Perform "Periodic Maintenance" as specified in Owners Manual.

4.3. Use reasonable care in maintenance, operation, use and storage of the product in accordance with the instructions contained in the owner's manual.

4.4. If the product fails because of defects in the manufacturer's material or workmanship within one (1) year of the date of purchase, return the product and dated proof of purchase to the Powerwinch dealer for replacement.

**THIS WARRANTY GIVES THE OWNER SPECIFIC LEGAL RIGHTS. THE LAWS OF CERTAIN JURISDICTIONS MAY GRANT THE OWNER ADDITIONAL RIGHTS AND PRIVILEGES.** Except as set forth above; SFEG makes no warranty, whether statutory or otherwise, including without limitation, any warranty of merchantability or fitness for a particular purpose. SFEG shall have no liability except to repair, replace or adjust defective products and parts. SFEG specifically excludes any liability, whether in contract, tort or otherwise, for personal injury, property damage, economic or consequential losses. SFEG has not authorized any person or company to alter the terms of this warranty.

It is SFEG's policy and practice to continuously improve the company's products and services. Therefore, SFEG reserves the right to make changes in design and components, without notice, whenever it is believed the quality of the product will be improved, but without incurring any obligation to incorporate such improvements in any product, which has been shipped, or in service.

**FOR YOUR RECORDS:**

**DEALER/INSTALLER**

**NAME:** \_\_\_\_\_

**ADDRESS:** \_\_\_\_\_

\_\_\_\_\_

\_\_\_\_\_

**PHONE:** \_\_\_\_\_

**PURCHASE DATE:** \_\_\_\_\_

**PART NUMBER:** \_\_\_\_\_

**SERIAL NUMBER:** \_\_\_\_\_

**PRODUCT NAME** \_\_\_\_\_

**OR DESCRIPTION:** \_\_\_\_\_

\_\_\_\_\_

***Retain your original proof of purchase.  
It is required for all warranty repairs and returns.***

**NOTES:**

\_\_\_\_\_

\_\_\_\_\_

\_\_\_\_\_

\_\_\_\_\_

\_\_\_\_\_

\_\_\_\_\_

**PROPRIETARY STATEMENT**

The *Powerwinch Motorized Folding Camper Winch* is a product of Scott Fetzer Electrical Group, located in Fairview, Tennessee, USA. The information contained in or disclosed in this document is considered proprietary to SFEG. Every effort has been made to ensure that the information presented in the document is accurate and complete. However, SFEG assumes no liability for errors or for any damages that result from the use of this document.

The information contained in this manual pertains to the current configuration of the model(s) listed on the title page. Earlier model configurations may differ from the information given. SFEG reserves the right to cancel, change, alter or add any parts and assemblies, described in this manual, without prior notice.

SFEG agrees to allow the reproduction of this document for use with SFEG products only. Any other reproduction or translation of this document in whole or part is strictly prohibited without prior written approval from SFEG.



[www.powerwinch.com](http://www.powerwinch.com)