

Please read and save these instructions. Read carefully before attempting to assemble, install, operate or maintain the product described. Protect yourself and others by observing all safety information. Failure to comply with instructions could result in personal injury and/or property damage! Retain instructions for future reference.

Powerwinch® Pan Fisherman Anchor Winch

Unpacking

When unpacking, inspect carefully for any damage that may have occurred during transit. Make sure any loose fittings, bolts, etc., are tightened before putting unit into service.

General Safety Issues

Used throughout this manual are four signal words to define safety issues. We use these words in this manual to help you avoid dangerous situations. These words are:

⚠ DANGER Danger means a hazard that will cause death or serious injury if the warning is ignored.

⚠ WARNING Warning means a hazard that could cause death or serious injury if the warning is ignored.

⚠ CAUTION Caution means a hazard that may cause minor or moderate injury if the warning is ignored. It also may mean a hazard that will only cause damage to property.

NOTE: Note means any additional information pertaining to the product or its proper usage.

General Safety Issues

Read all manuals included with this product carefully. Be thoroughly familiar with the controls and the proper use of the equipment. Only persons well acquainted with these rules of safe operation should be allowed to use the winch.

⚠ DANGER Rope breakage and whiplash hazard.

1. Never stand between the load point and the winch. If the rope breaks it could snap back with enough force to cause severe injury or death.

2. The winch is shipped with a closed loop anchor roller. If the included anchor roller is ever replaced it must be replaced by a closed loop anchor roller. The closed loop anchor roller will prevent the anchor line from snapping onto the boat deck in the event the rope breaks.
3. Always use nylon rope specifically rated for this product. Never substitute cable for rope. Cable is not an acceptable anchor line because it does not stretch and is easily frayed. If cable breaks it can snap back with more force than nylon rope.
4. This product is intended to lift only river & lake anchors. Do not attempt to lift or move people or other objects with this winch.
5. Inspect entire rope for weak or worn condition or kinking (short tight twist or curl) before each use. Replace worn rope with nylon rope specifically rated for this product.

⚠ DANGER Electrical shock and fire hazards.

1. Do not use electrical wire sizes other than those specified in this manual. Using wire that is too small could result in overloading and a fire.
2. Use only the supplied or recommended circuit breakers when installing this winch. Using incorrect circuit breakers could result in a fire.
3. Use only marine grade, fully tinned wire for electrical connections between the battery and the winch.
4. Make sure any crimped electrical connectors meet manufacturer's strength requirements.
5. Always disconnect the wiring harness from the battery before attempting to install, relocate, or service the winch.

⚠ DANGER Cruising and boat trailering hazards.

1. When the boat is cruising or being trailered, the anchor must be tied to a cleat (or other secure point) and secured with the safety chain. If the anchor breaks free during cruising or trailering, it will cause serious damage and/or injury.

⚠ WARNING Anchoring hazards.

1. Always tie the anchor line off to a cleat (or other secure point) when the boat is anchored. The winch must not be used to hold the load of the boat while anchored. Serious damage to the motor and/or failure of the winch could occur.
2. Do not pull a load greater than the rating for the winch. If the circuit breaker halts operation of the winch during retrieval or deployment, the winch may have been overloaded and serious damage could result.

⚠ WARNING Entanglement hazards.

1. Never place any object or tool in the rope spool while retrieving or deploying the anchor. The tool or object could become tangled in the rope resulting in serious injury and/or damage to the winch.
2. Do not wear loose fitting clothing, scarves, or neck ties during the operation of the winch. Loose clothing may become caught in moving parts resulting in injury or death.
3. Do not operate the winch under the influence of drugs and/or alcohol.

Winch Description

The Pan Fisherman anchor winch retrieves and deploys river and lake anchors using nylon rope. This anchor winch features power-in and power-out operation with a switch that can be mounted on the helm. See Chart 1 for winch specifications. The Pan Fisherman anchor winch has an anchor roller that must be installed before the winch is installed.

Pan Fisherman Anchor Winch

Installation

TOOLS REQUIRED:

1. Electric drill
2. Punch
3. 5/16" & 13/64" drill bits
4. Terminal crimping tool
5. Adjustable wrench
6. Philips head screwdriver

Chart 1 Product Specifications

Model	Max. Anchor Weight	No Load Line Speed (Ft/min)	Line Size Type and Length	Motor Voltage	Circuit Breaker	Unit Weight	Dimensions (LxWxH)
Pan Fisherman	20 lbs.	70	3/16" dia. Nylon x 100'	12 v	15A	13 lbs.	11"x9.5"x7"

MATERIALS REQUIRED (NOT INCLUDED)

1. Four 1/4" bolts and nuts. Bolt length depends upon deck thickness.
2. Four 1/2" diameter flat washers.
3. Three 10-32 bolts and nuts. Bolt length depends on deck thickness
4. Four #10 washers
5. Four 6-32 screws for the switch mounting plate. Screw length depends on location.
6. Shackle for anchor attachment.
7. Anchor.
8. Two battery terminals.
9. #8 AWG or #10 AWG wire. Wire gage depends on length of run.
8. Four #8-#10 insulated flange terminals
9. One #8-#10 ring terminal for a #10 stud size.
10. One #8-#10 ring terminal for a 5/16" stud.
11. Two #8-#10 insulated butt connectors.

1. Locate anchor roller on deck in desired location. Note the anchor roller must be located on the edge of the deck for proper fit.
2. Go below the deck and check for any obstructions underneath the desired anchor roller location.
3. Using a punch, mark the three anchor roller mounting holes on the deck.
4. Remove anchor roller. Using a 13/64" drill bit, drill the three holes.
5. Secure the anchor roller to the deck using three 10-32 bolts, nuts and #10 washers.
6. Align the centerline of the anchor roller with the centerline of the rope spool marked on the template.
7. Go below the deck and check for any obstructions underneath the desired anchor winch mounting location
8. Spot and drill the holes as shown on the template. There are four 5/16" mounting holes and one 5/16" hole for the motor leads. See Figure 1.
9. Place the anchor winch in position and bolt to the deck. To ensure the greatest strength, use fender washers and/or marine plywood under the deck to ensure the greatest strength and to spread the load.

WIRING SELECTION & SPECIFICATION

⚠ DANGER Do not use electrical wire sizes or types other than those specified in this manual. Using wire that is too small could result in overloading and a fire.

Estimate wire length needed to run from the battery to the switch and from the switch to the anchor winch. The total wire length is defined as battery to switch, switch to anchor winch, plus the reverse direction. If the total wire length is less than 50 ft., use #10AWG. If the total wire length is greater than 50 ft., use #8 AWG.

REMOTE SWITCH INSTALLATION AND WIRING

⚠ DANGER Use only the supplied or recommended circuit breakers when installing this winch. Using incorrect circuit breakers will result in a fire.

⚠ DANGER Always disconnect the wiring harness from the battery before attempting to install, relocate, or service the winch.

⚠ DANGER Make sure all crimped electrical connectors meet manufacturer's strength requirements

⚠ CAUTION Follow order of wiring steps to ensure power is not applied to anchor winch until all wires and circuit breakers are installed.

⚠ CAUTION Always keep wires away from intense sources of heat. Be sure newly installed wires are away from any exposed bare wires.

⚠ CAUTION Never attach the circuit breaker to the negative terminal of the battery. Refer to Figure 2

1. Select a suitable location (console, etc.) to locate switch. Make sure there is enough room behind switch mounting surface for entire switch and wires.
2. Cut a rectangle 1 1/2" high and 1" wide. Attach the switch to the mounting plate and slide into cut. Secure the switchplate with the four #6-32 screws.
3. Attach the busbar to the circuit breaker using the supplied locknut. Attach the circuit breaker to the positive(+) battery post.
4. Measure and cut the required red and black wire lengths to connect the battery to the switch.
5. Crimp the small (#10) ring terminal to one end of the red wire and a female disconnect to the other end.
6. Crimp the large (5/16") ring terminal to one end of the black wire and a female disconnect to the other end.
7. Attach the ring terminal on the red wire to the unused post on the circuit breaker using a nut.
8. Connect the female disconnect on the red wire to Terminal "C" on the back of the switch.
9. Connect the ring terminal on the black wire to the negative (-) battery post.
10. Connect the female disconnect on the black wire to Terminal "D" on the back of the switch.

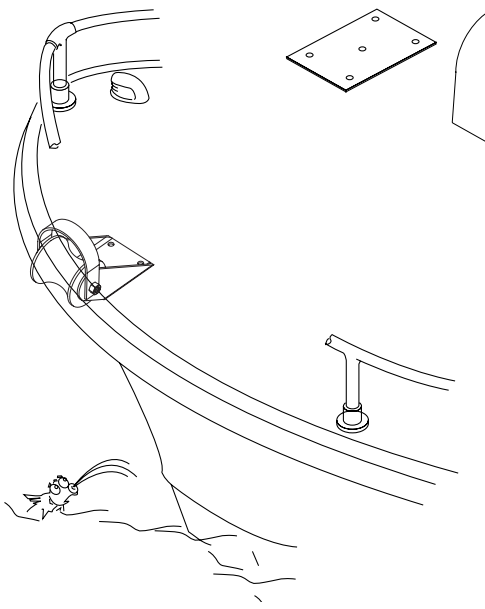

Figure 1. Pan Fisherman Mounting

MOUNTING ANCHOR WINCH ONTO DECK

The anchor winch can be mounted on the fore (front) or the aft (rear) of the boat. It is important that the supplied anchor roller line up with the centerline of the rope spool for proper operation. To mount the anchor winch, refer to Figure 1 and follow the procedures outlined below.

11. Measure and cut the required red and black wire to connect the anchor winch to the switch.
12. Crimp a female disconnect to one end of both red and black wires.
13. Connect the female disconnect on the red wire to Terminal "B" on the back of the switch.
14. Attach the red wire to the red motor lead on the anchor winch using a butt connector.
15. Connect the female disconnect on the black wire to Terminal "A" on the back of the switch.
16. Attach the black wire to the black Motor lead on the anchor winch using a butt connector.

3. Pull the rope back until the knot is seated in the countersunk opening.
4. Keep tension on the rope and feed the rope on the drum by running the anchor winch with the switch in the up position. Correct rotation is essential for proper operation. Make sure the rope rotation corresponds to Figure 3. The rope must feed from the top of the drum.

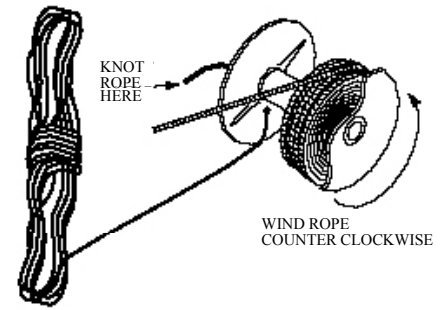

Figure 3. Rope Installation

Anchor Attachment

Use a river or lake type anchor up to a maximum weight of 20 lb. Do not exceed this weight or the anchor winch will not operate correctly.

Attach the anchor to a shackle (not supplied) as shown in Figure 4. Powerwinch has found through experience that the best method of attaching the anchor line to the anchor is to use a knot.

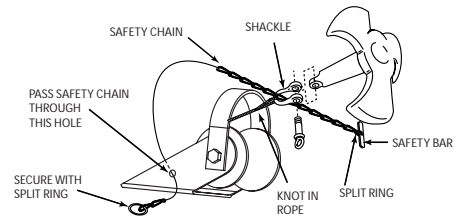

Figure 4. Anchor Attachment

Rope Installation

CAUTION The rope must be tied in an overhand knot to secure the rope on the drum. If rope is not securely tied to the drum, personal injury and/or product damage could occur if the anchor would break free from the spool while under load.

To install rope on the drum, refer to Figure 3 and follow the outlined procedures.

1. Insert the rope through the hole located in the side of the drum (from the side opposite of the countersunk hole)
2. Feed enough rope through to tie an overhand knot at the end of the rope.

CAUTION The knot must be securely fastened and tested by the end user before anchoring.

Safety Chain Attachment

DANGER When the boat is cruising or being trailered, the anchor must be tied to a cleat (or other secure point) and secured with the safety chain. If the anchor breaks free during cruising or trailering, it will cause serious damage and/or injury.

The safety chain is designed to hold the anchor in place when the anchor winch is not in use. See Figure 4 and follow the procedures outlined below to attach a safety chain.

1. Feed one end of the chain through the hole in the side of the anchor roller housing.

Safety Chain Attachment Continued

Remove as many links as necessary to obtain a tight fit to the anchor. Attach the chain to the anchor roller housing using a split ring.

2. Attach the safety bar to the safety chain with a split ring.
3. Insert the safety bar completely through the anchor eye or shackle. Position the bar perpendicular to the anchor.

Anchor Winch Operation

The anchor winch is simple to operate. To lower the anchor press and hold the switch in the "down" position. To raise the anchor, press and hold the switch in the "up" position.

CAUTION Never change the switch direction without allowing the motor to come to a complete stop. Motor damage could occur and the warranty will be void.

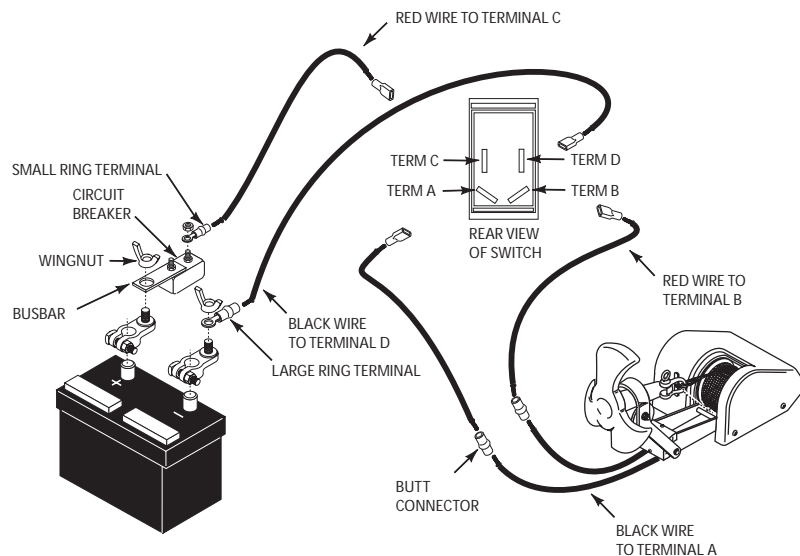

Figure 2. Pan Fisherman Wiring

Pan Fisherman Anchor Winch Maintenance

The anchor winch does not require any lubrication. However, the rope must be checked periodically for abrasion or cuts. Also check the connection between the shackle and the rope for wear.

Pan Fisherman Anchor Winch Technical Information

For technical information regarding the operation or repair of this product, please call 1-800-793-4793 or write:
 Powerwinch
 2268 Fairview Blvd.
 Fairview, TN 37062

Genuine Pan Fisherman Anchor Winch Replacement Parts Information

For information regarding where to order genuine replacement parts, call 1-800-793-4793. Please have available the model number, serial number, and part number with description.

General Trouble Shooting Guide for Pan Fisherman

Symptom	Possible Cause(s)	Corrective Action
Anchor Winch will not operate	<ol style="list-style-type: none"> 1. Disconnected, bad wiring, or faulty circuit breaker. 2. Anchor too heavy. 3. Improper rope rotation. 	<ol style="list-style-type: none"> 1. Visually check each electrical connection. If you are experienced in checking electrical circuits with a volt meter, you may want to check each connection with the switch engaged. Check circuit breaker connection closely. 2. Use anchors weighing 20 pounds or less. 3. See rope installation instructions. Rope should wind from over the top of the rope spool.

LIMITED WARRANTY

- A. This Limited Warranty is given by the Powerwinch Division of the Scott Fetzer Company (the “Company”) to the original purchaser (the “Purchaser”) of a Powerwinch Product (the “Product”) specified in this manual. This Limited Warranty is not transferable to any other party.
- B. Responsibilities of the Company under this Limited Warranty:
1. Repair or replace (at the discretion of the Company) any part or parts of the Product found by the Company to be defective within a 2 year period from the date of purchase.
 2. The Company will pay the transportation charge for shipment back to the Purchaser of any Product received for legitimate Warranty repair.
- C. Responsibilities of the Purchaser under this Limited Warranty:
1. Purchaser will have to show dated proof of purchase to qualify for service under the provisions of the Limited Warranty.
 2. Promptly notify the Seller or the Company of any claim hereunder.
 3. At the Option of the Company, return the Product to the Company for inspection. Authorization must be given prior to any Product return. Call the Company at 1-800-793-4793 or write the Company at 2268 Fairview Blvd., Fairview, TN 37062, for authorization and complete instructions on how to return the Product directly to the Company.
 4. Use reasonable care in maintenance, operation, use and storage of the Product in accordance with the instructions contained in the Owner’s Manual.
 5. Have Warranty work performed by a dealer or representative approved by the Company.
 6. Except as noted in B.2., transportation charges are the responsibility of the Purchaser.
- D. This Limited Warranty covers:
1. Defects in workmanship or materials.
 2. Any part or parts of the Product sold or manufactured by the Company.
- E. This Limited Warranty does not cover:
1. Any failure that results from improper installation of the Product.
 2. Any failure that results from accident, Purchaser’s abuse, neglect, modification, improper maintenance, or failure to operate and use the Product in accordance with the instructions provided in the Owner’s Manual supplied with the Product.
- F. There is no other express warranty. Implied warranties, including those of merchantability and fitness for a particular purpose, are limited to one (1) year from date of purchase. This is the exclusive remedy and any liability for any and all incidental or consequential damages or expenses whatsoever is excluded. Some states do not allow limitations on how long an implied warranty lasts, or do not allow exclusion or limitation of incidental or consequential damages, the above limitations may not apply to you.
- This Limited Warranty gives you specific legal rights, and you may also have other rights which vary from state to state. Powerwinch reserves the right to alter specifications on any product without notice.
- All rights reserved. This publication or parts thereof may not be reproduced in any form without written permission.
-

Powerwinch®

Pan Fisherman Anchor Winch REPLACEMENT PARTS LIST

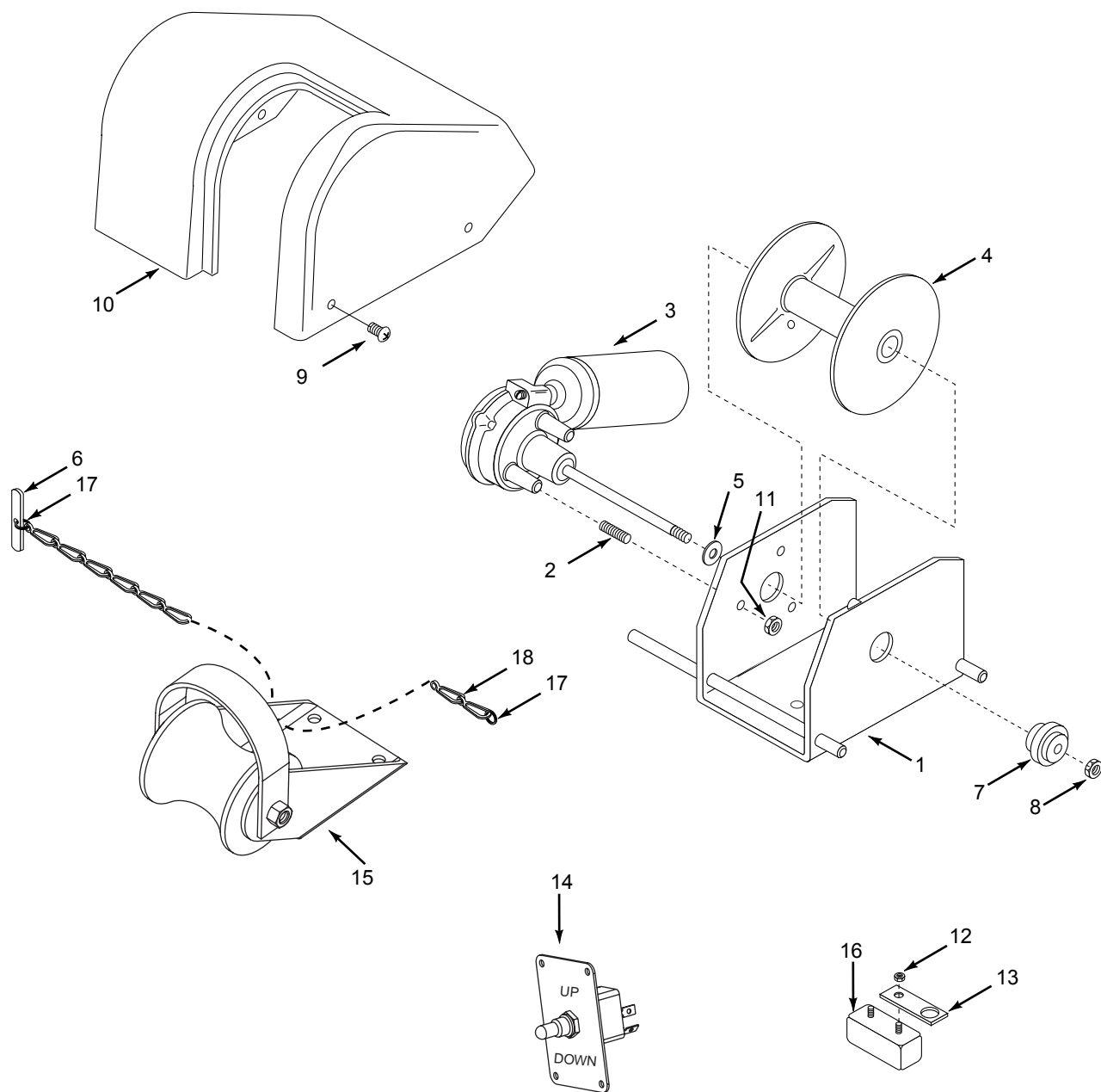

PAN FISHERMAN ANCHOR WINCH

Replacement Parts List

REF NUMBER	DESCRIPTION	PART NUMBER	QTY
1	FRAME	P70141	1
2	MOUNTING STUD	ST070559AV	3
3	MOTOR/GEARBOX ASSY	P11035	1
4	ROPE SPOOL	P73714	1
5	WASHER 3/4"x7/16"x1/16"	P79811	5
6	SAFETY BAR	P76255	1
7	BEARING	P71623	1
8	LOCK-NUT 7/16"-20	P79731	1
9	COVER SCREW #10-32x3/8"	P79558	4
10	COVER	P74022	1
11	MOUNTING STUD NUT	P79728	3
12	LOCK-NUT #10-32	P79701	2
13	BUSBAR	P78121	1
14	SWITCH ASSEMBLY	P10851	1
15	ANCHOR ROLLER ASSEMBLY	P10953	1
16	CIRCUIT BREAKER	P78201	1
17	SPLIT RING	P79737	2
18	SAFETY CHAIN	P73733	1

Replacement Parts Information

For information regarding where to order replacement parts, call 1-800-793-4793. Please provide the following information:

- Model Number
- Serial Number
- Part Number & Description

Address parts correspondence to:
 Powerwinch Customer Service
 2268 Fairview Blvd.
 Fairview, TN 37062

